

Schémas de Principe Electrique par Fonction

Page 2	Protection Electrique
Page 3	Répartition des Masses (habitacle 12V)
Page 4	Répartition des Masses (plateforme et habitacle 72V)
Page 5	Circuit de Démarrage
Page 6	Circuit de Charge
Page 7	Moteur
Page 8	Accelerateur
Page 9	Défaut Général
Page 10	Feux de Position
Page 11	Feux de Croisement/Route
Page 12	Feux de Recul
Page 13	Feux Stop
Page 14	Clignotants / Warnings
Page 15	Anti-Brouillard
Page 16	Feux Flash et Triangle
Page 17	Avertisseur Sonore
Page 18	Avertisseur de présence
Page 19	Essuie-Glace Avant
Page 20	Dégivrage Avant
Page 21	Voyants Information du Combiné de Bord
Page 22	Regulation Vitesse
Page 23	Auto Radio
Page 24	Allume Cigare
Page 25	Plafonnier
Page 26	Ventilation-Chauffage
Page 27	Siège Chauffant
Page 28	Frein Electrique
Page 29	Alarme Siège

Auteur :

Date :

Sommaire

Fichier :

Folio : 1/29

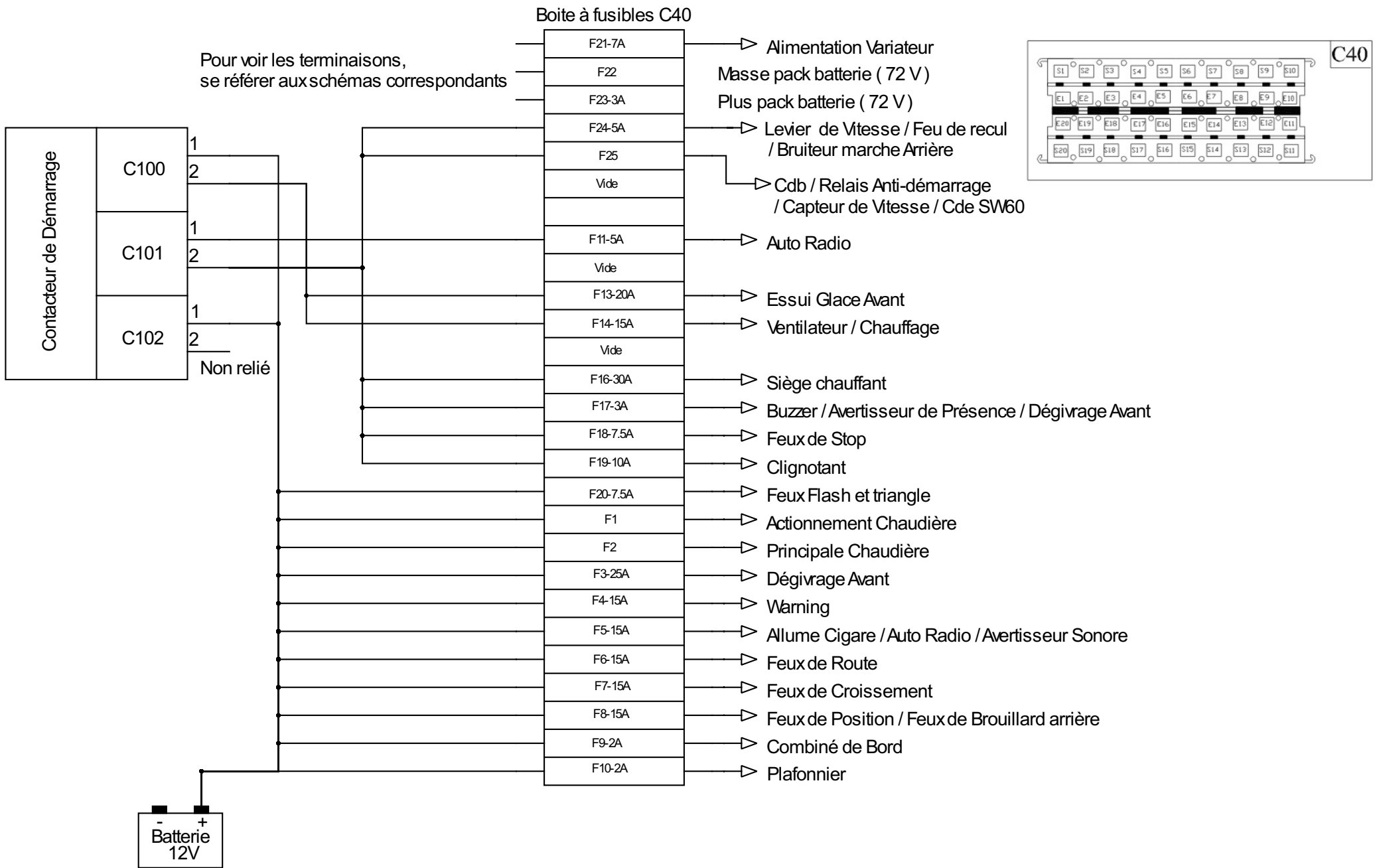

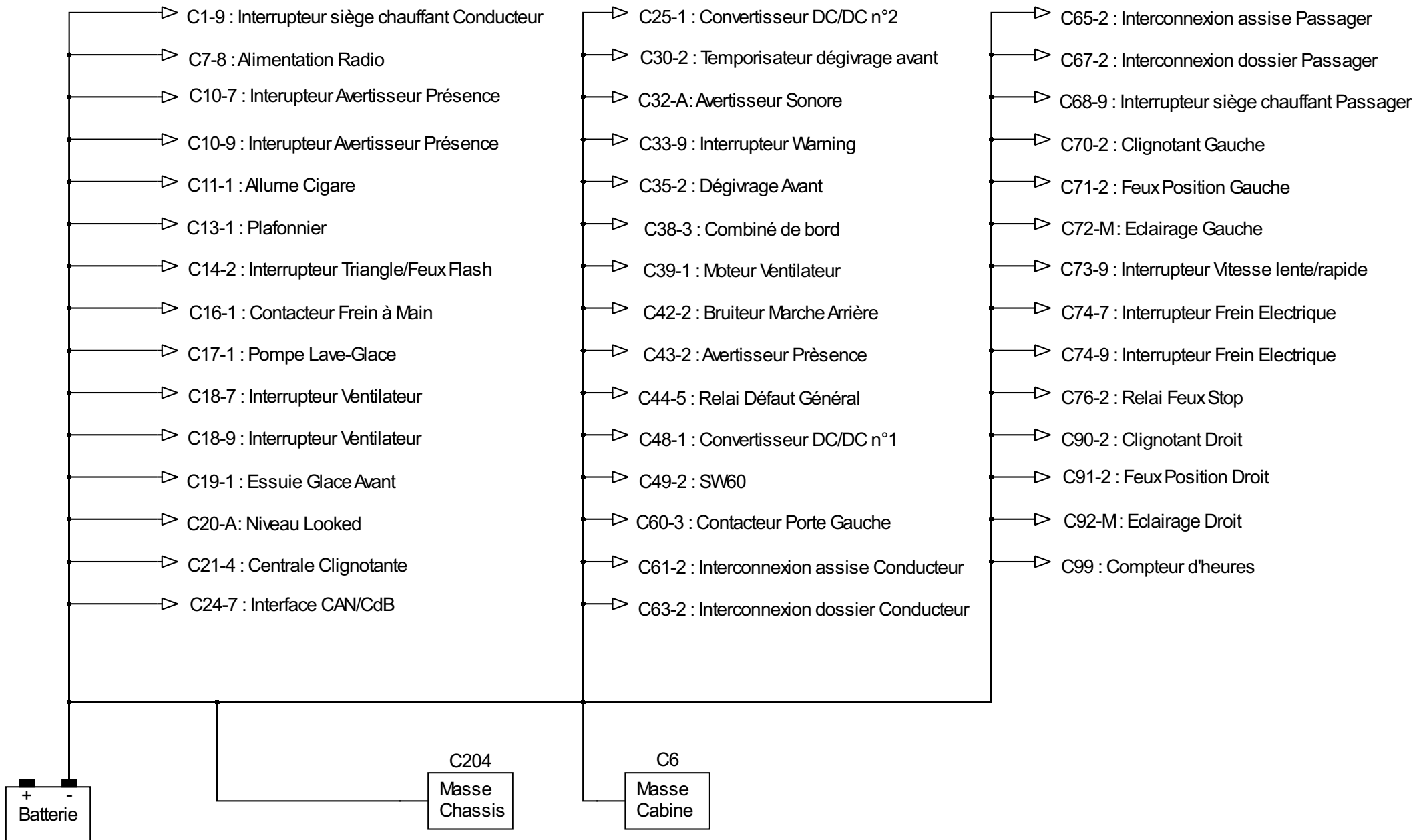

Habitacle

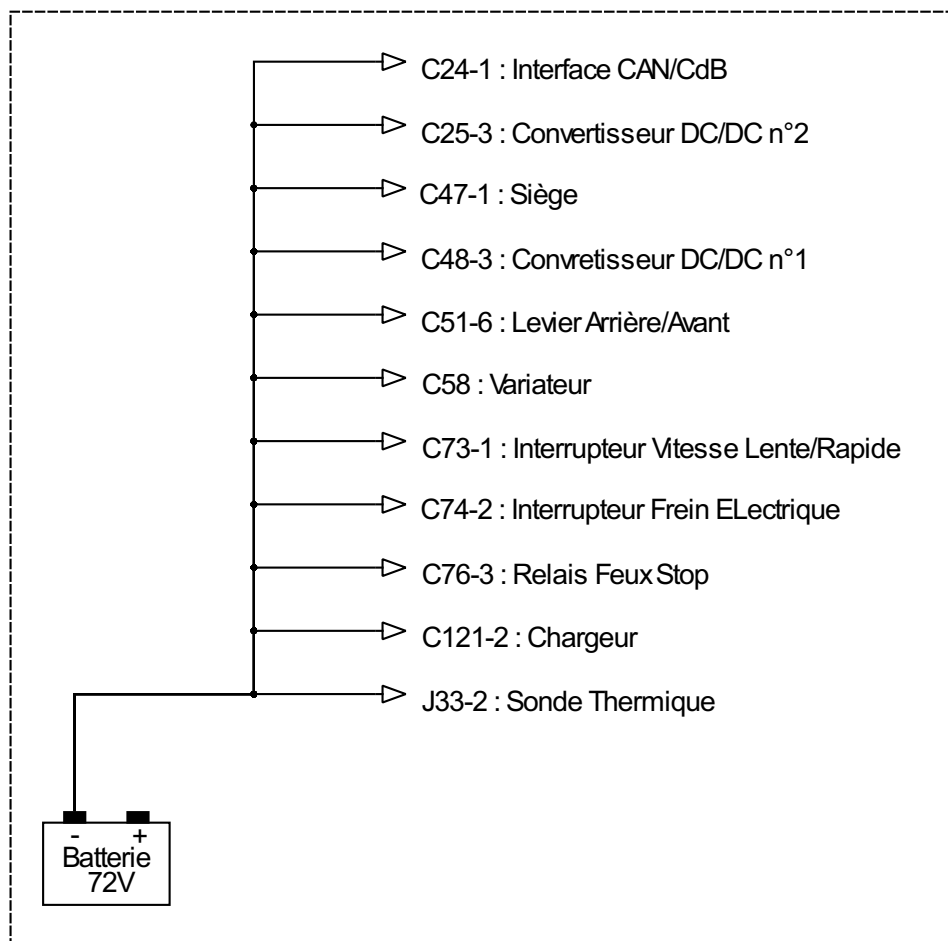

Plateforme

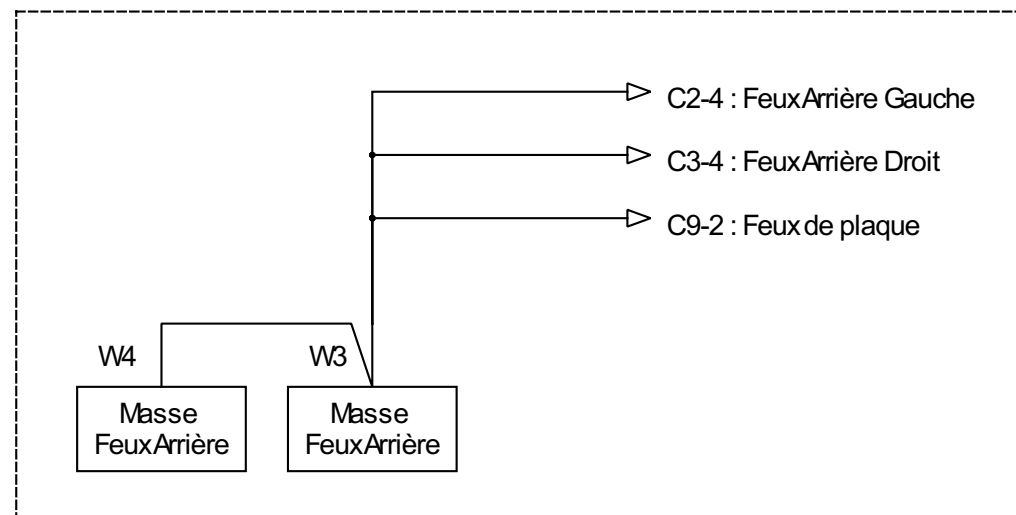

Auteur :

Date :

Répartition des Masses (plateforme et habitacle 72 V)

Fichier :

Folio : 4/29

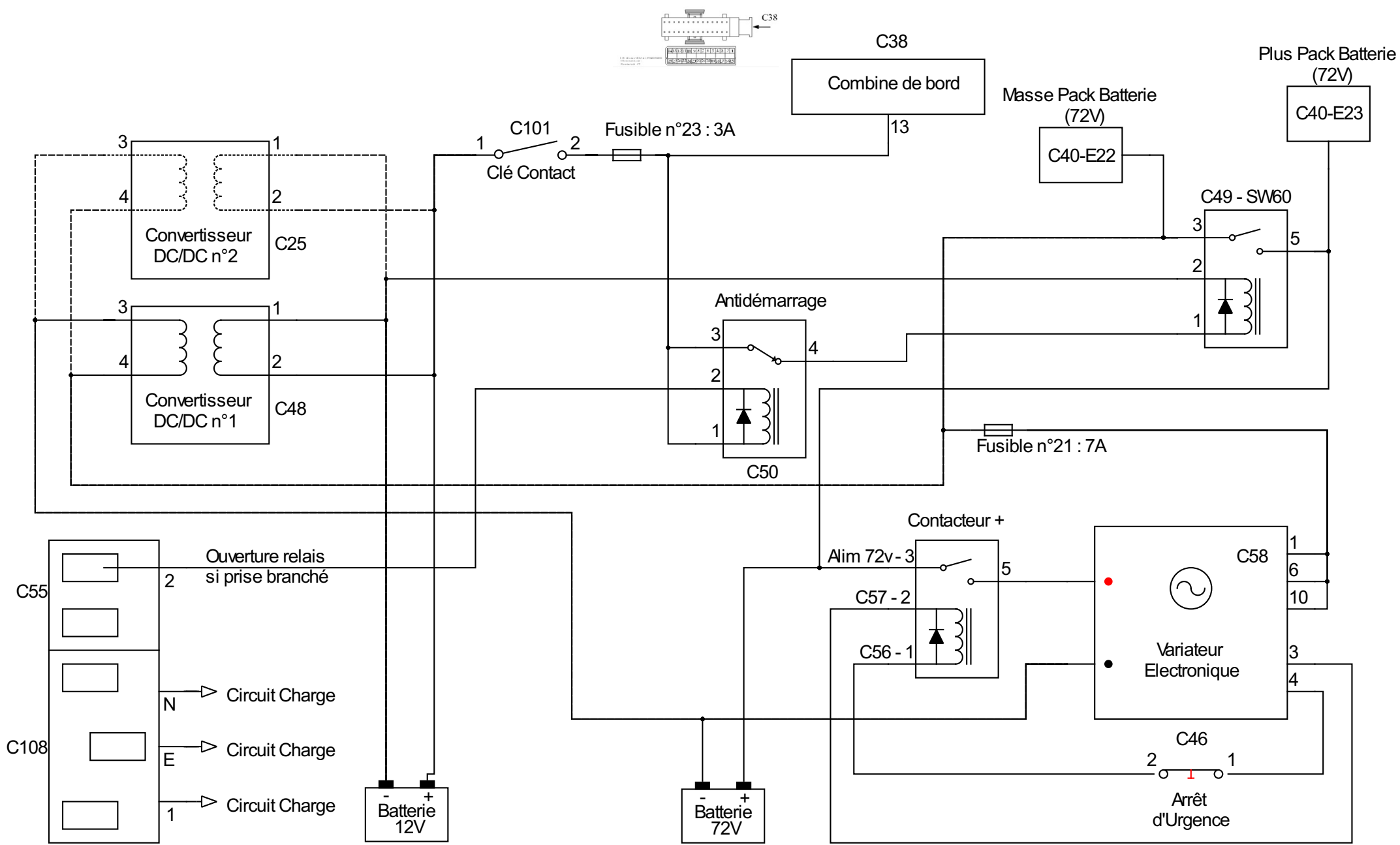

Auteur :
Date :

Circuit de Démarrage

Fichier :
Folio : 5/29

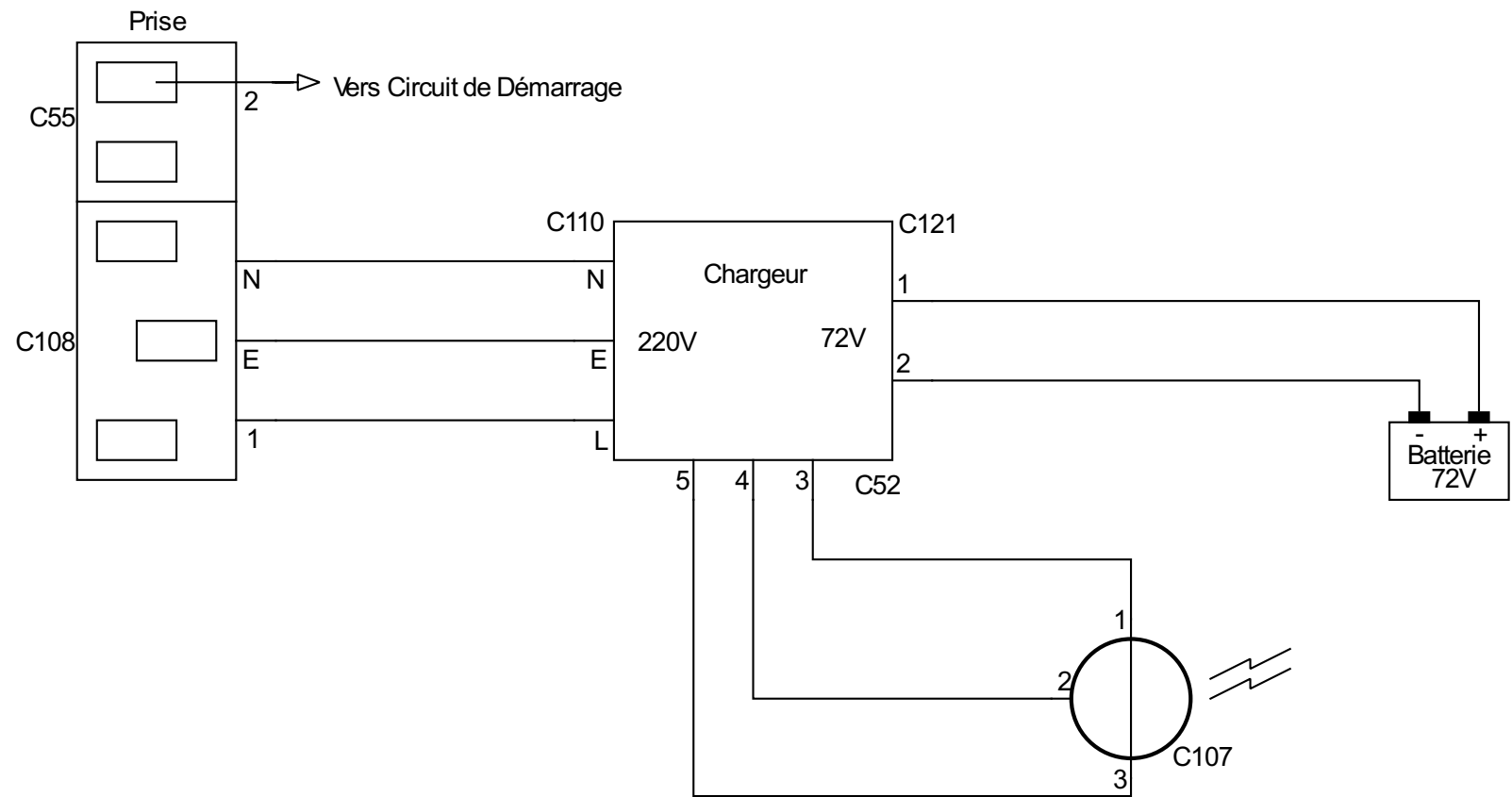

Auteur :
Date :

Circuit de charge

Fichier :
Folio : 6/29

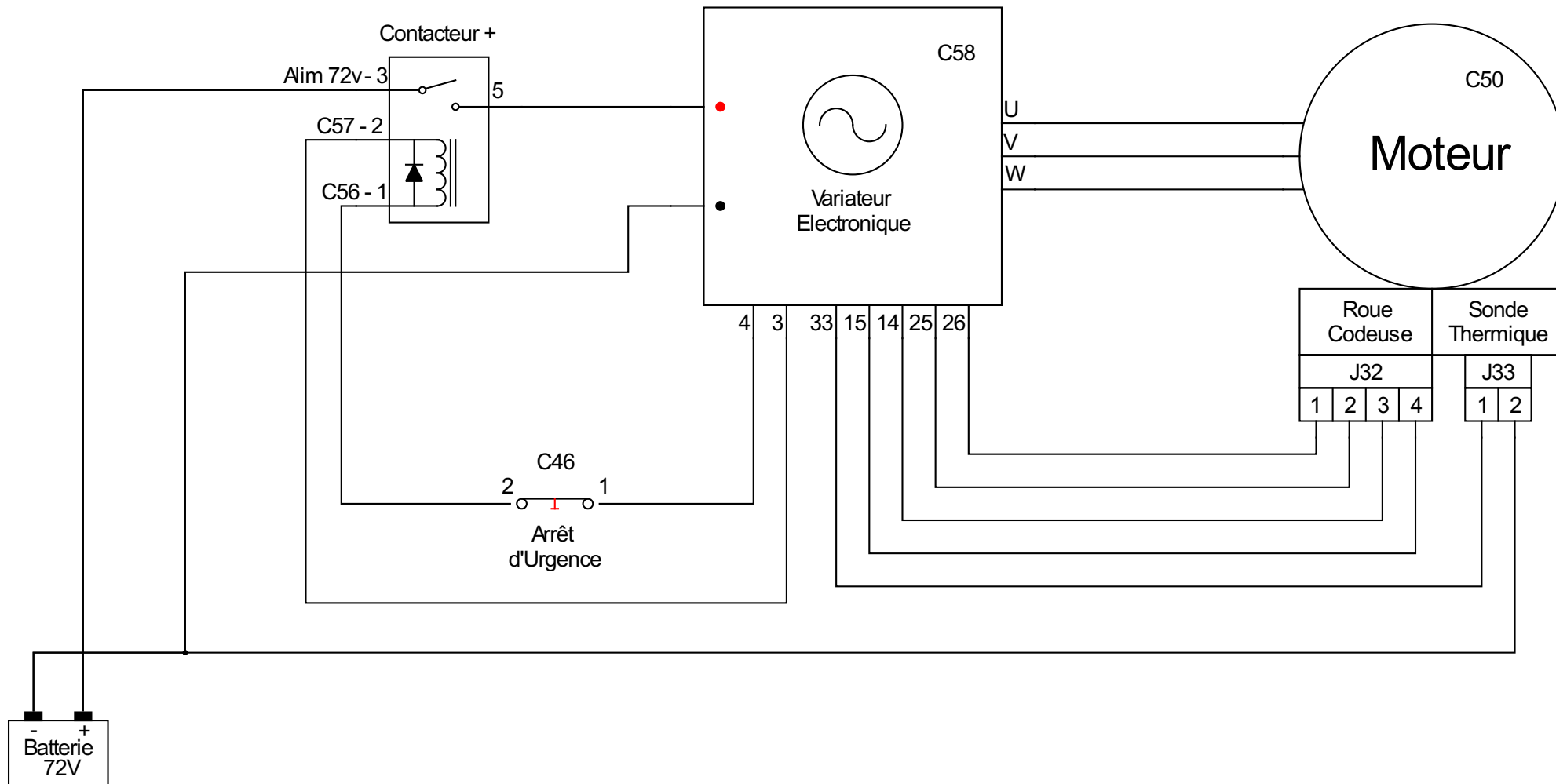

Auteur :
Date :

Moteur

Fichier :
Folio : 7/29

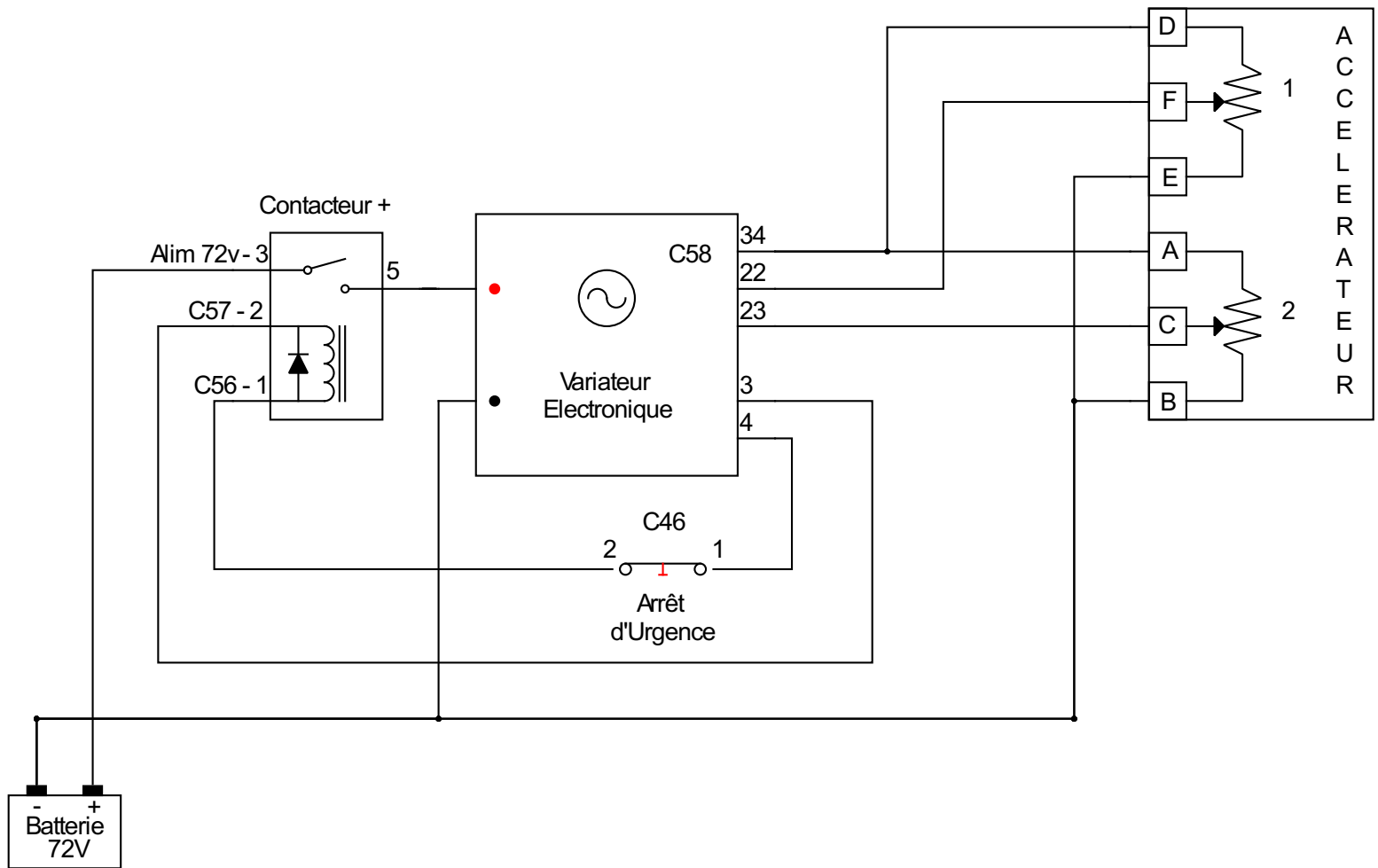

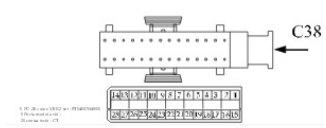
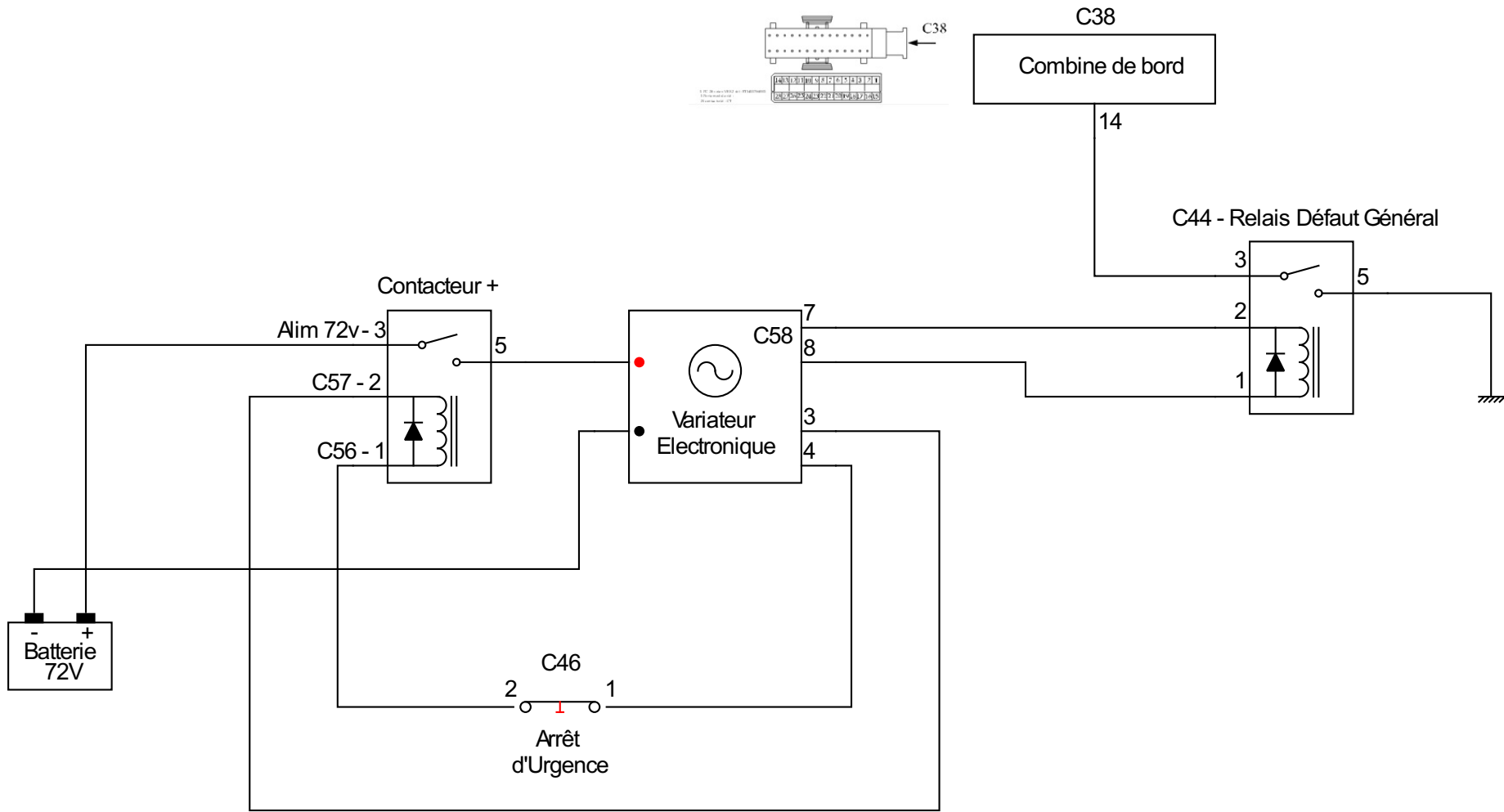

Auteur :	Défaut général	Fichier :
Date :		Folio : 9/29

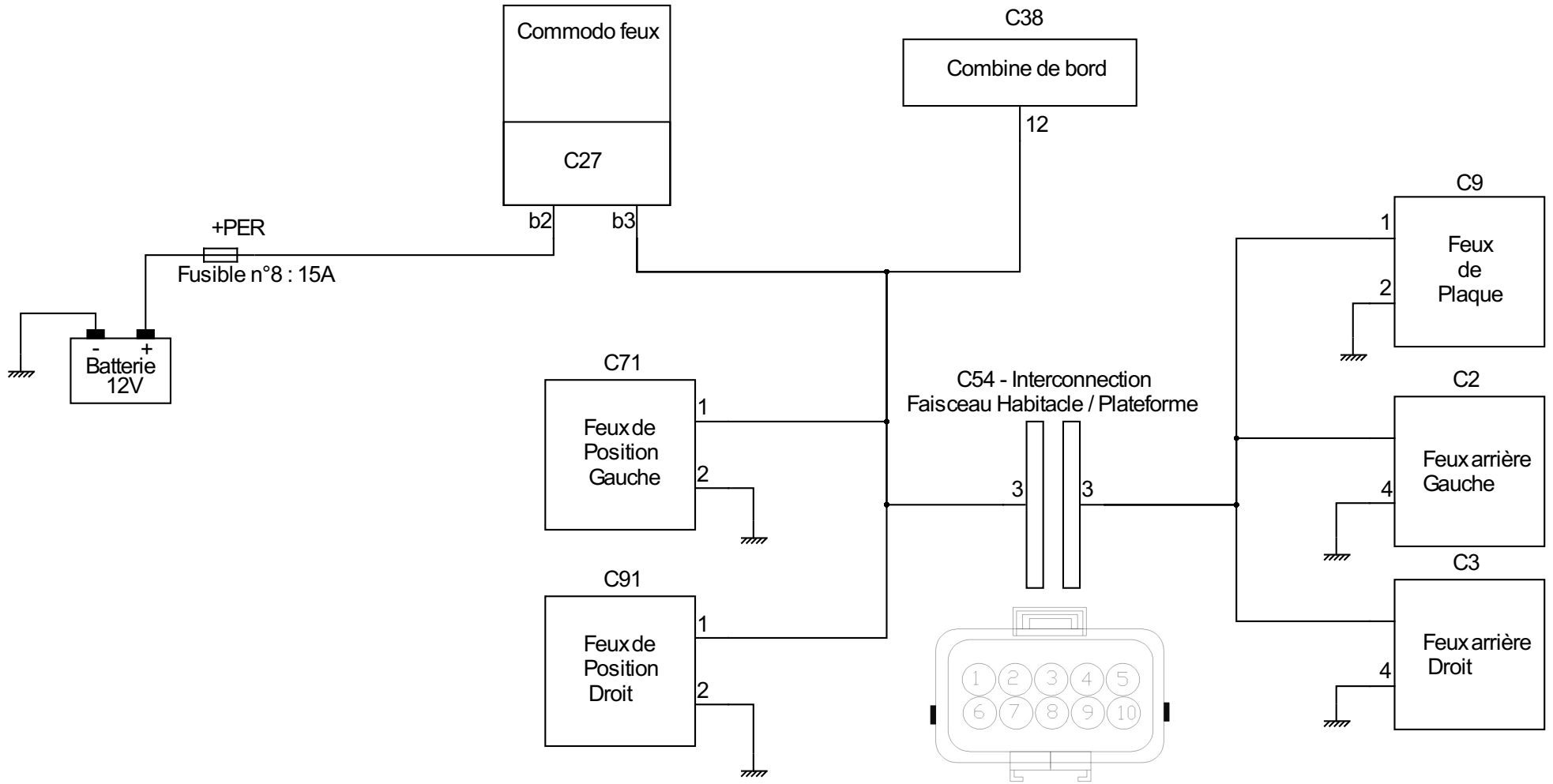
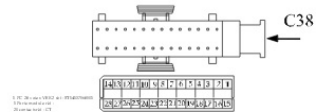
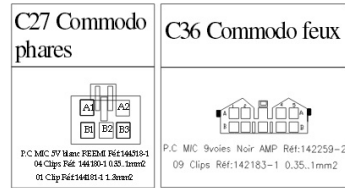

Auteur :
Date :

Feux de Position

Fichier :
Folio : 10/29

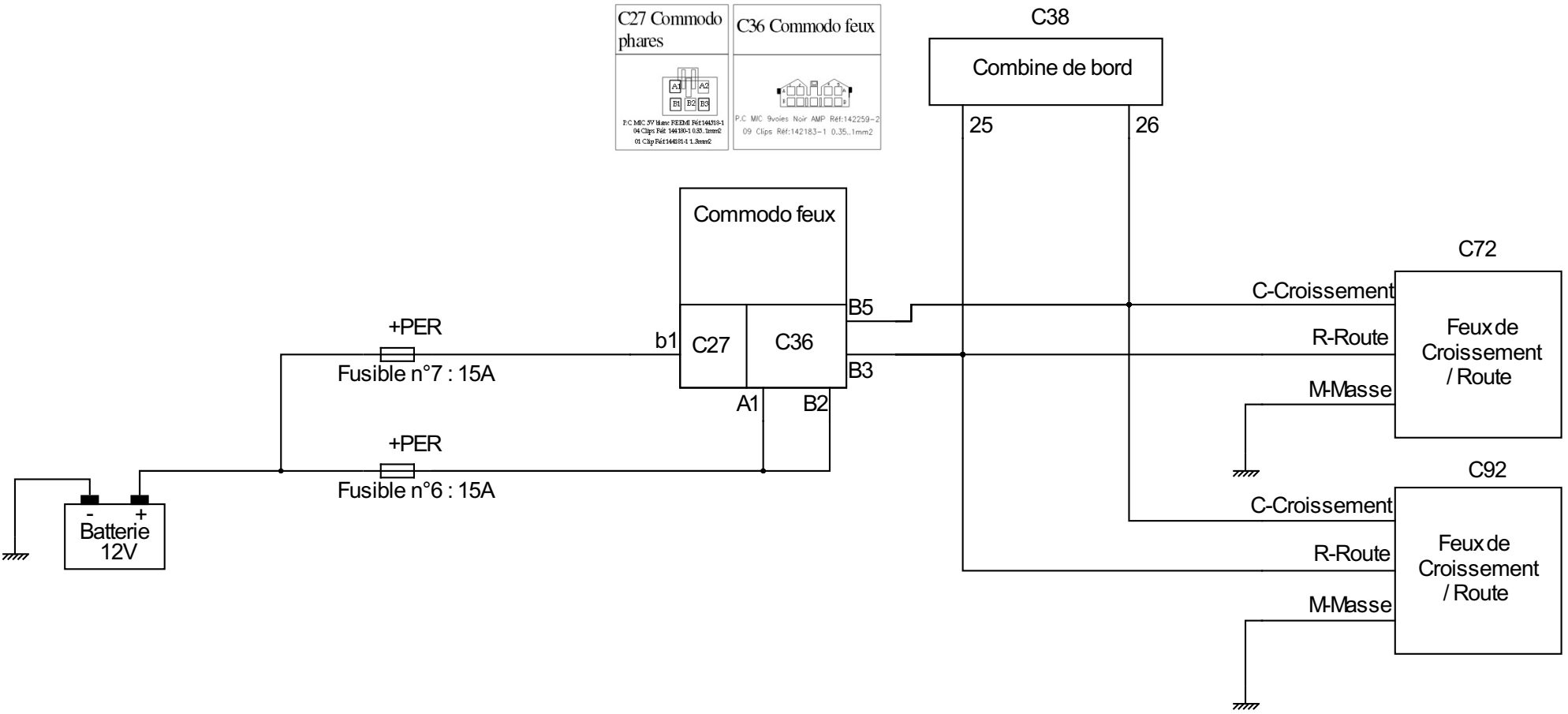
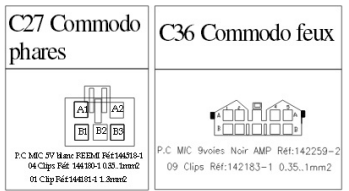
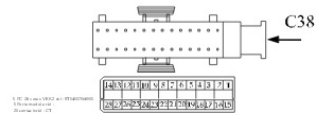

Auteur :
Date :

Feux de Croisement / Route

Fichier :
Folio : 11/29

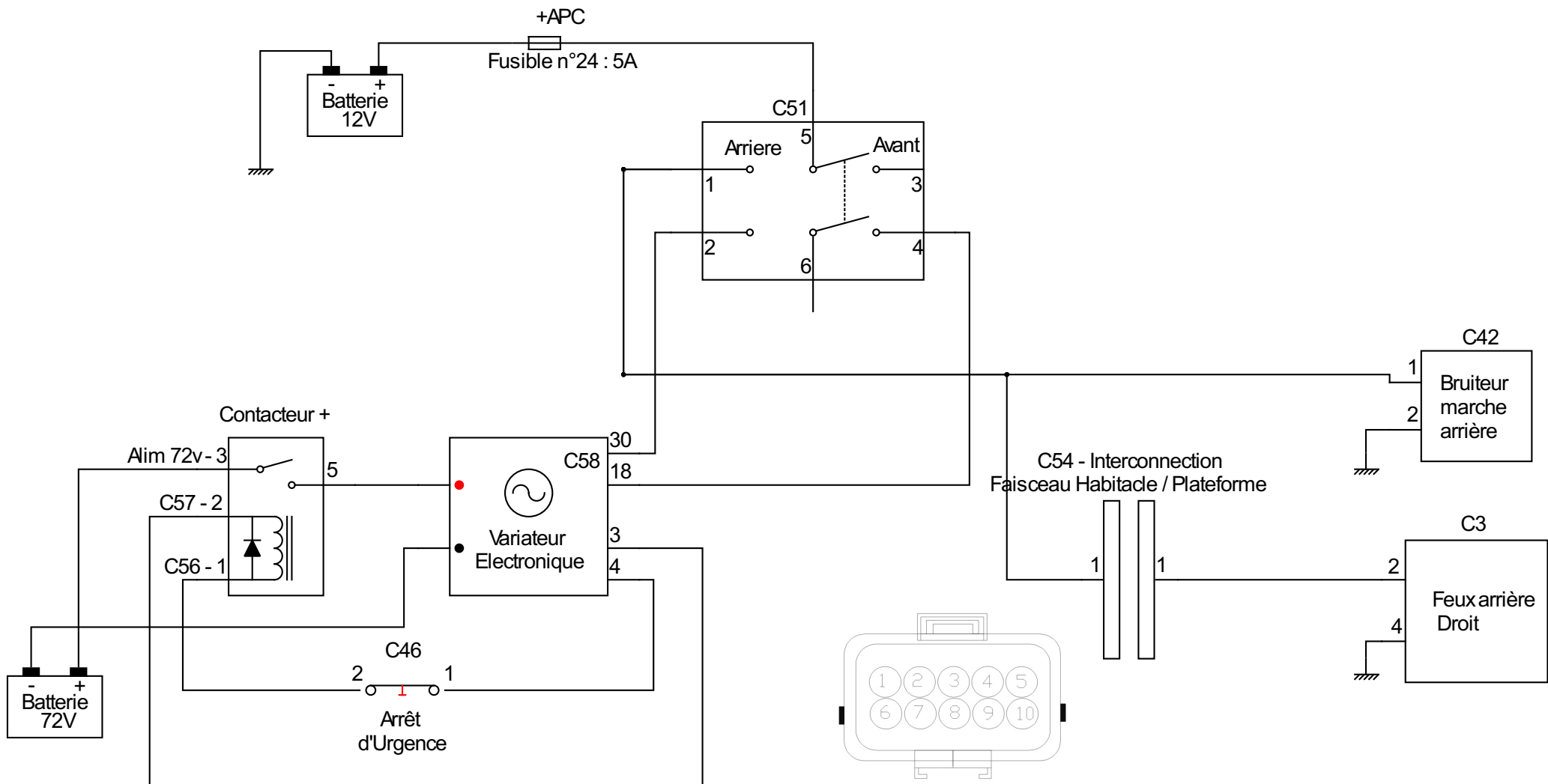

Auteur :

Date :

Feuxrecul

Fichier :

Folio : 12/29

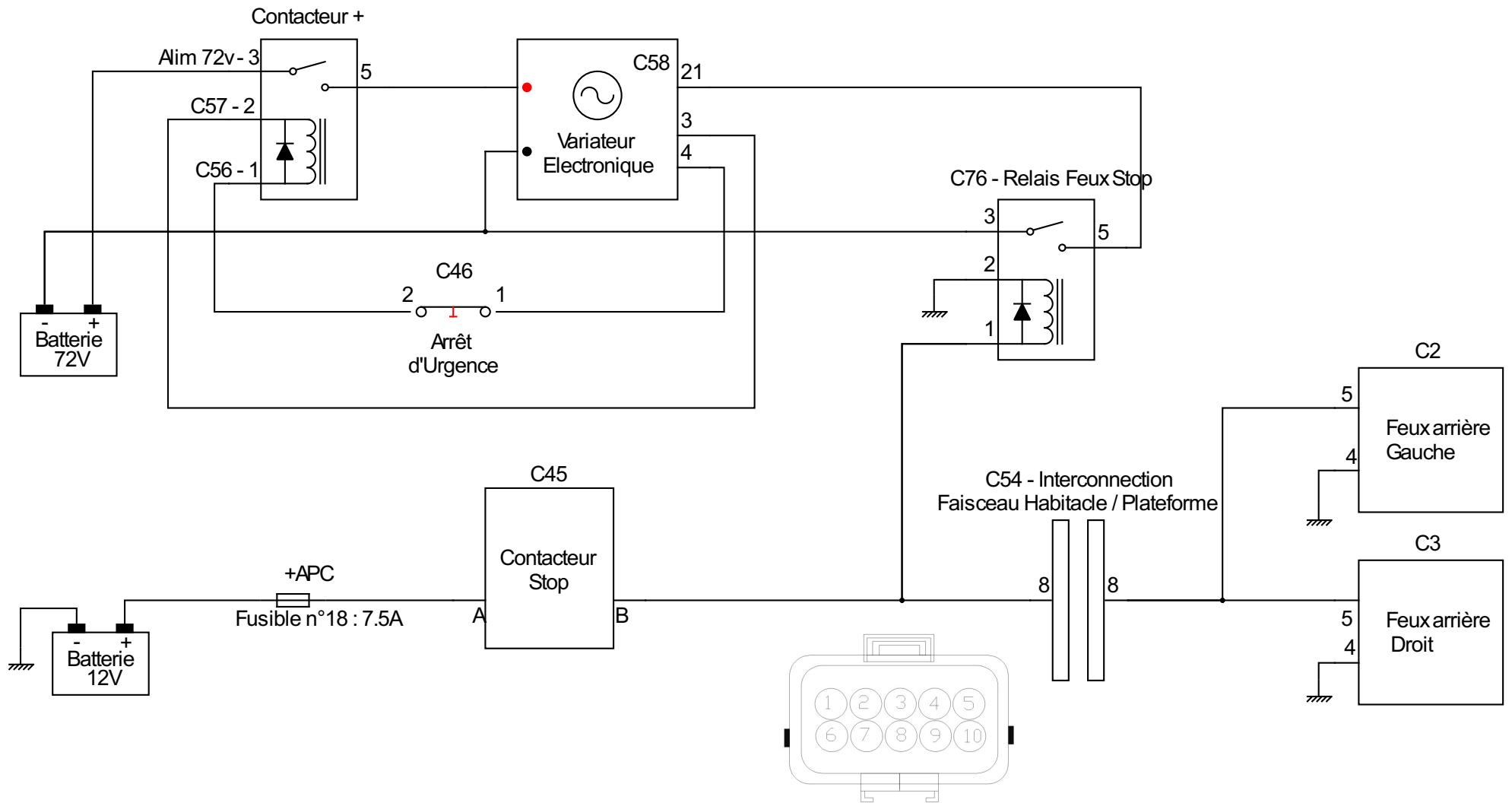

Auteur :
Date :

Feux Stop

Fichier :
Folio : 13/29

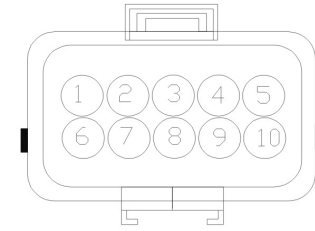
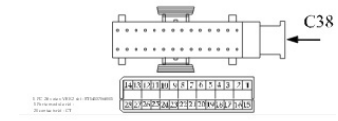
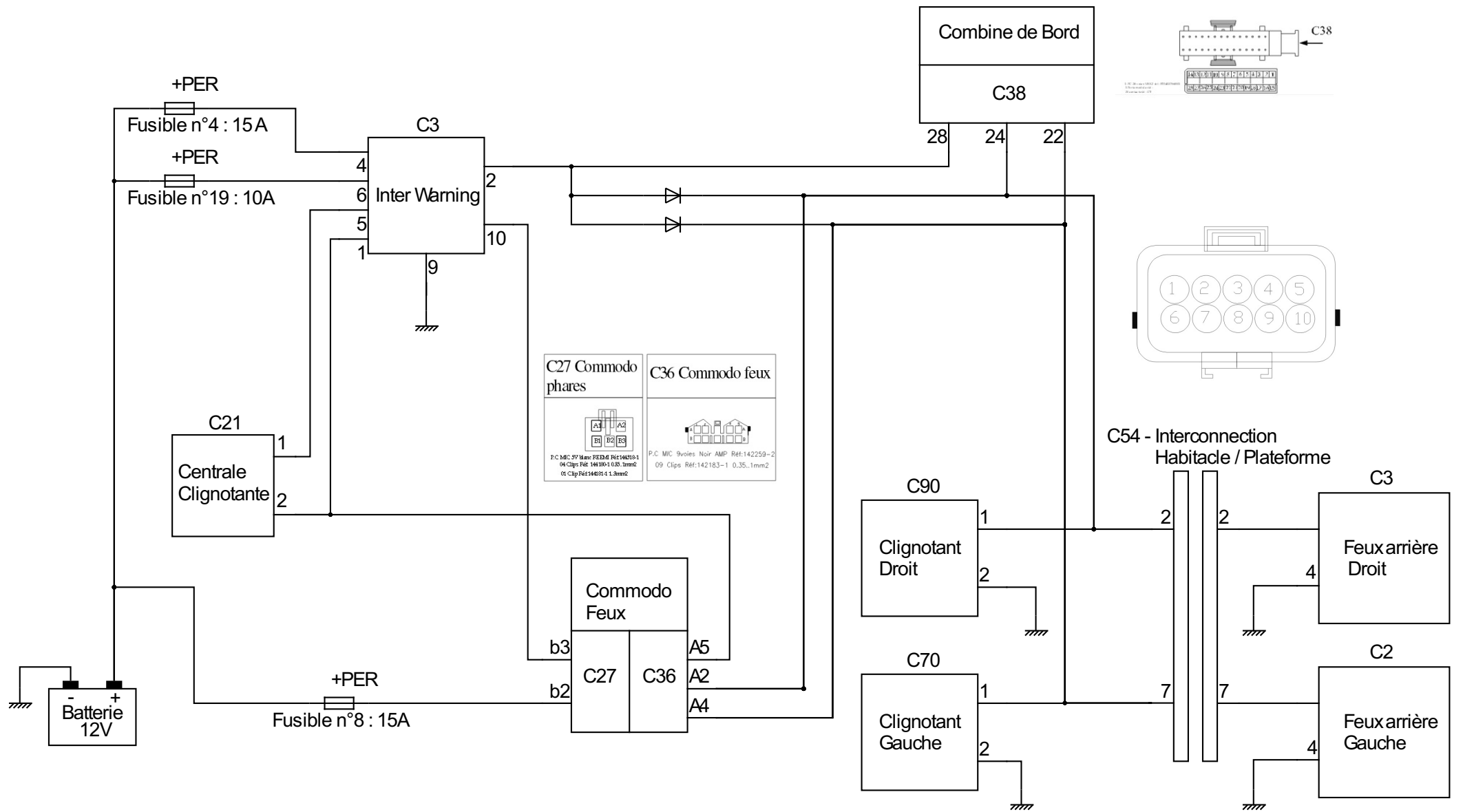

Auteur :
Date :

Clignotant / Warning

Fichier :
Folio : 14/29

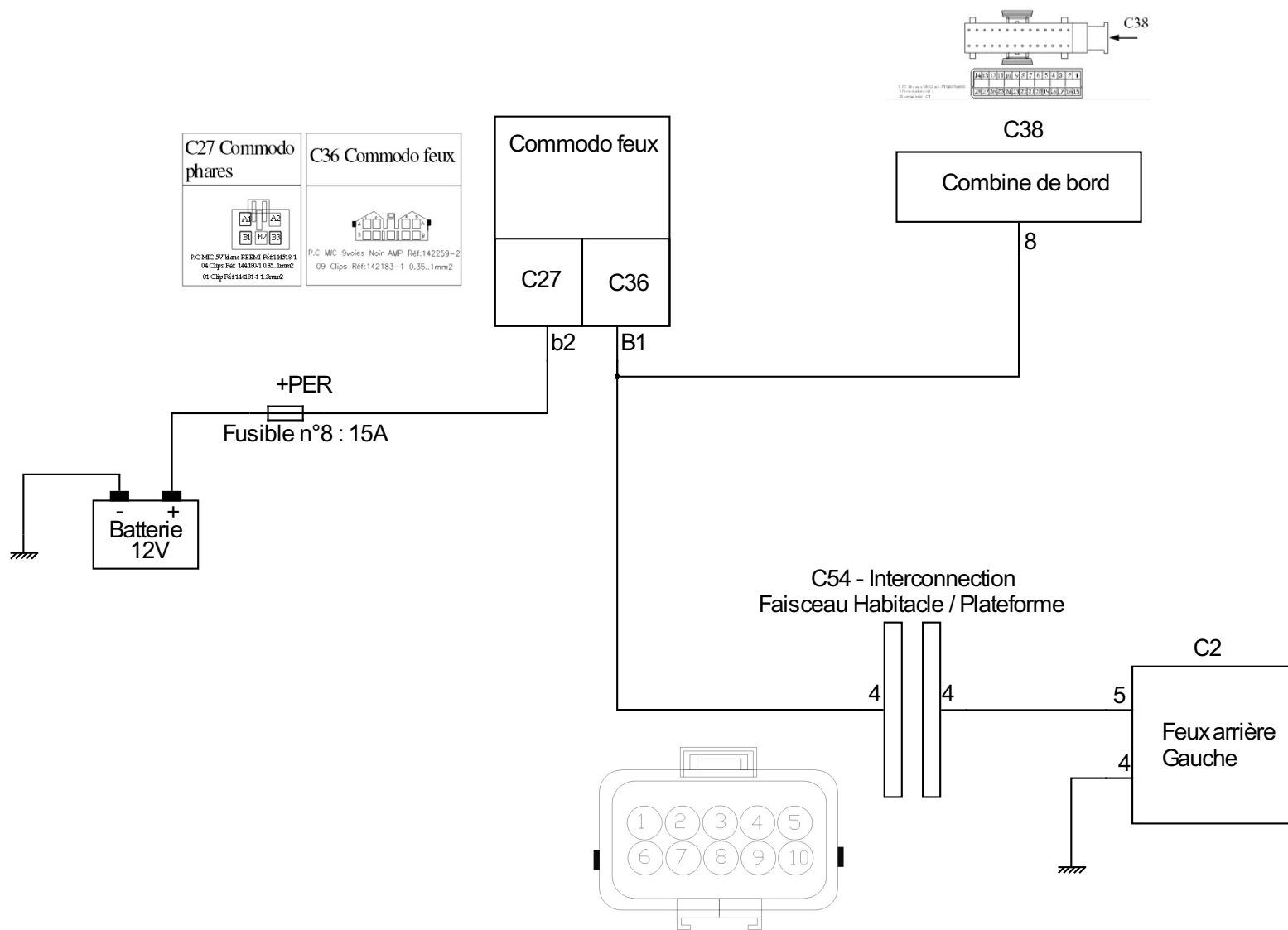

Auteur :
 Date :

FeuxAnti-Brouillard

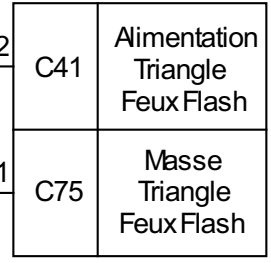
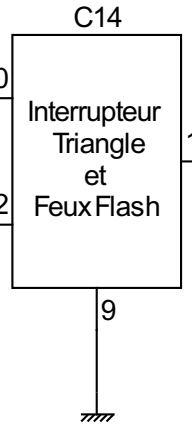
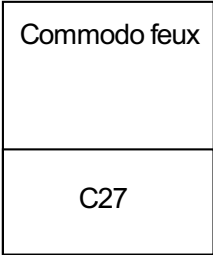
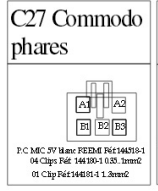
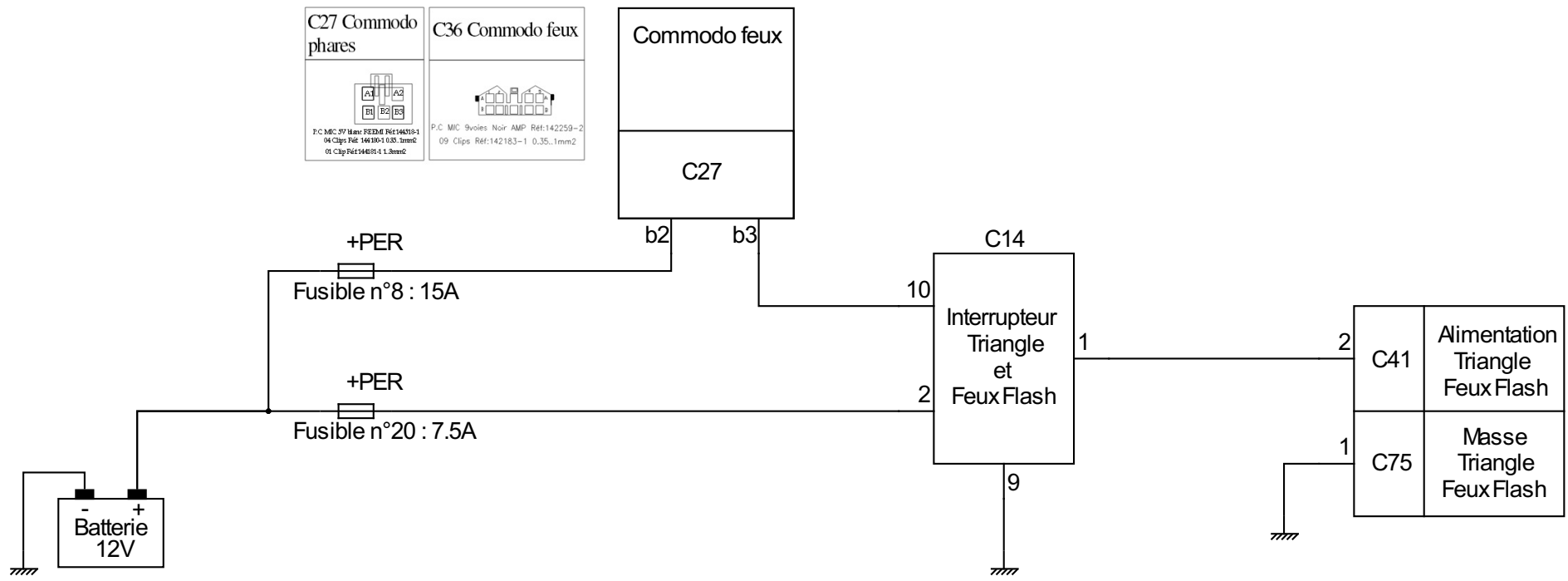

Fichier :
 Folio : 15/29



Auteur :
Date :

Feux Flash et Triangle

Fichier :
Folio : 16/29

<p>C27 Commodo phares</p>  <p>P.C. MIC. 9V. Hous: FE234E Réf:1445181-1 04 Clips Réf: 144180-1 0.25..1mm2 01 Clip Réf:144181-1 1.3mm2</p>	<p>C36 Commodo feux</p>  <p>P.C. MIC. 9voies Noir AMP. Réf:142259-2 09 Clips Réf:142183-1 0.35..1mm2</p>
---	---

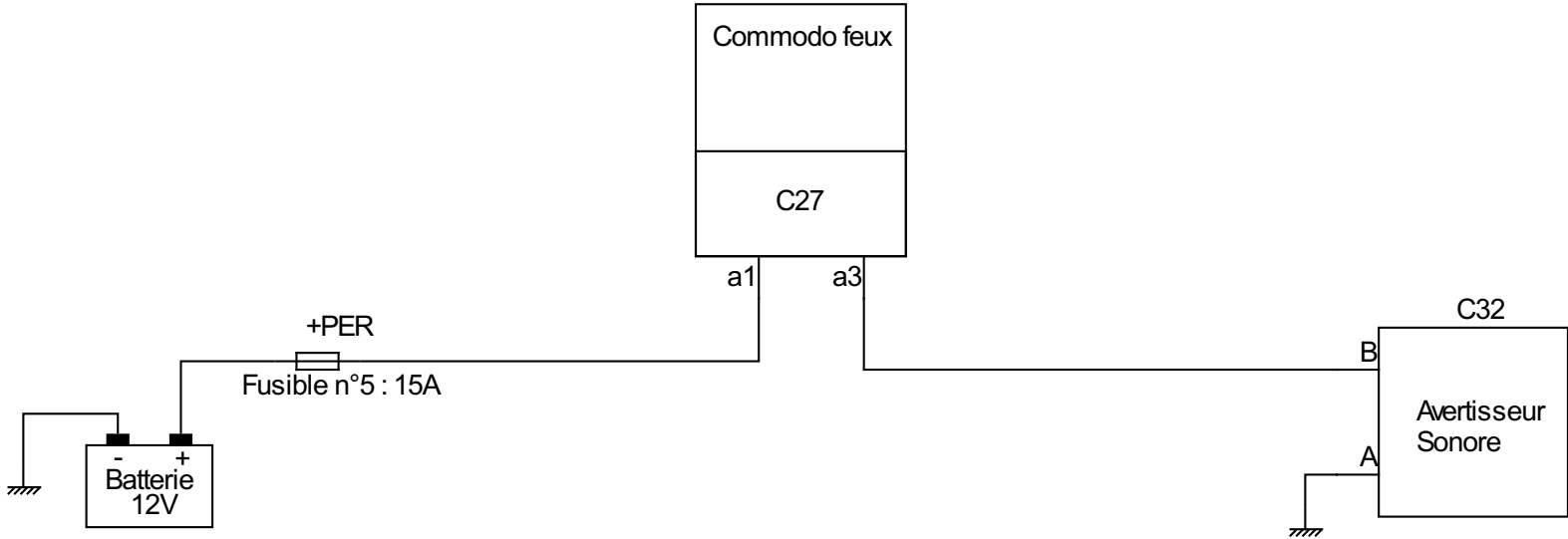

Auteur :	Avertisseur Sonore	Fichier :
Date :		Folio : 17/29

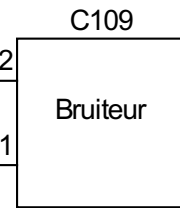
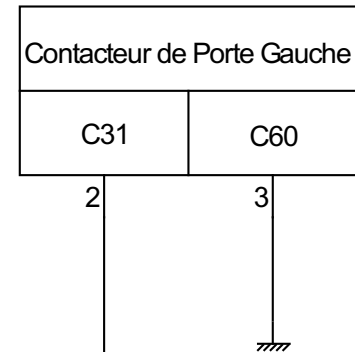
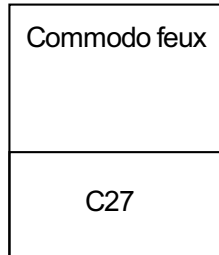
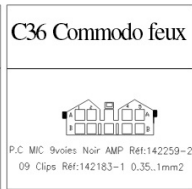
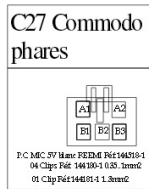
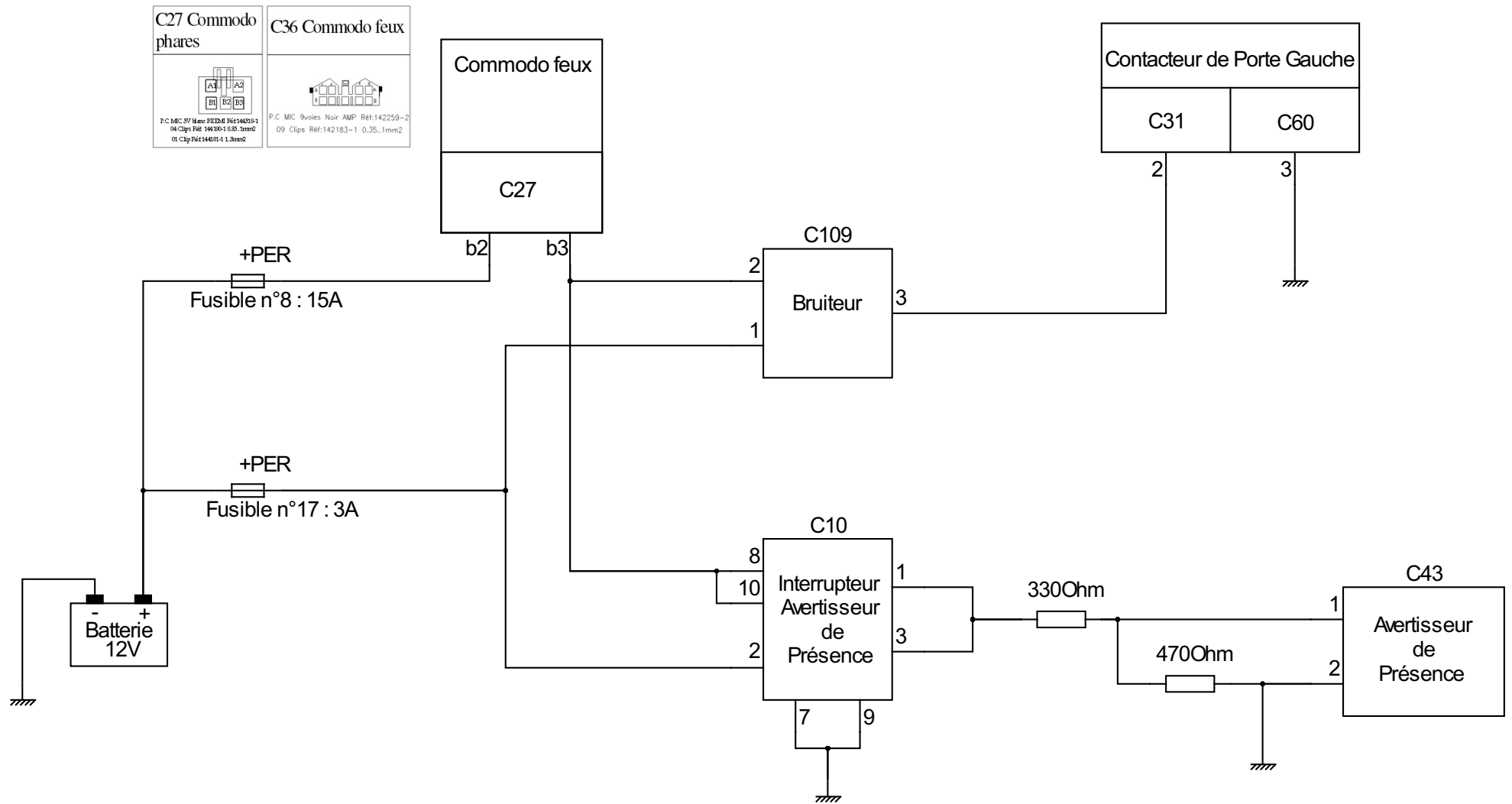

330Ohm

470Ohm

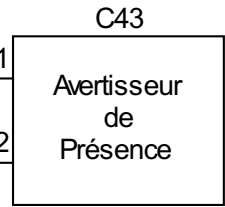

Auteur :
Date :

Avertisseur de présence

Fichier :
Folio : 18/29

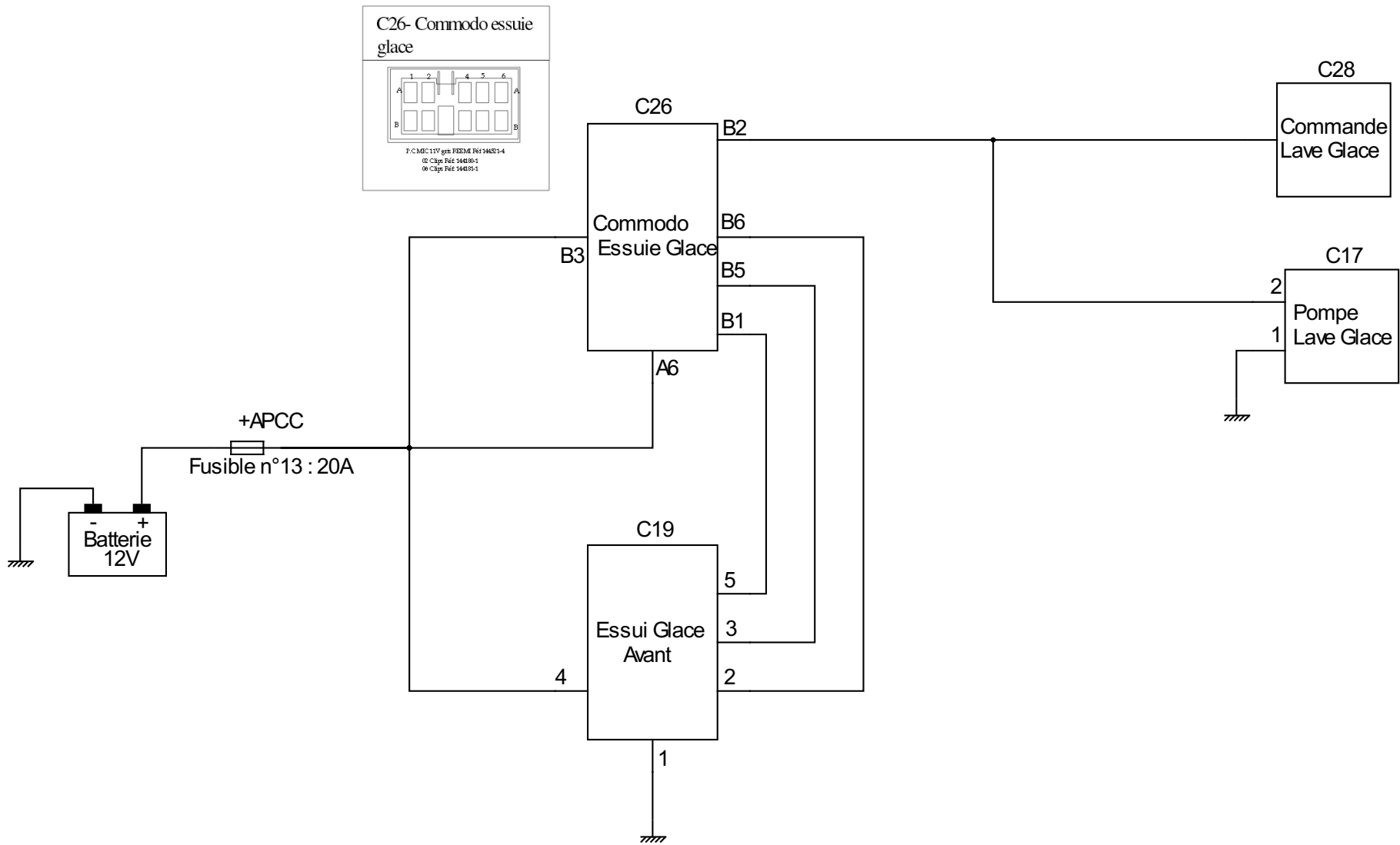

Auteur :	Essui Glace Avant	Fichier :
Date :		Folio : 19/29

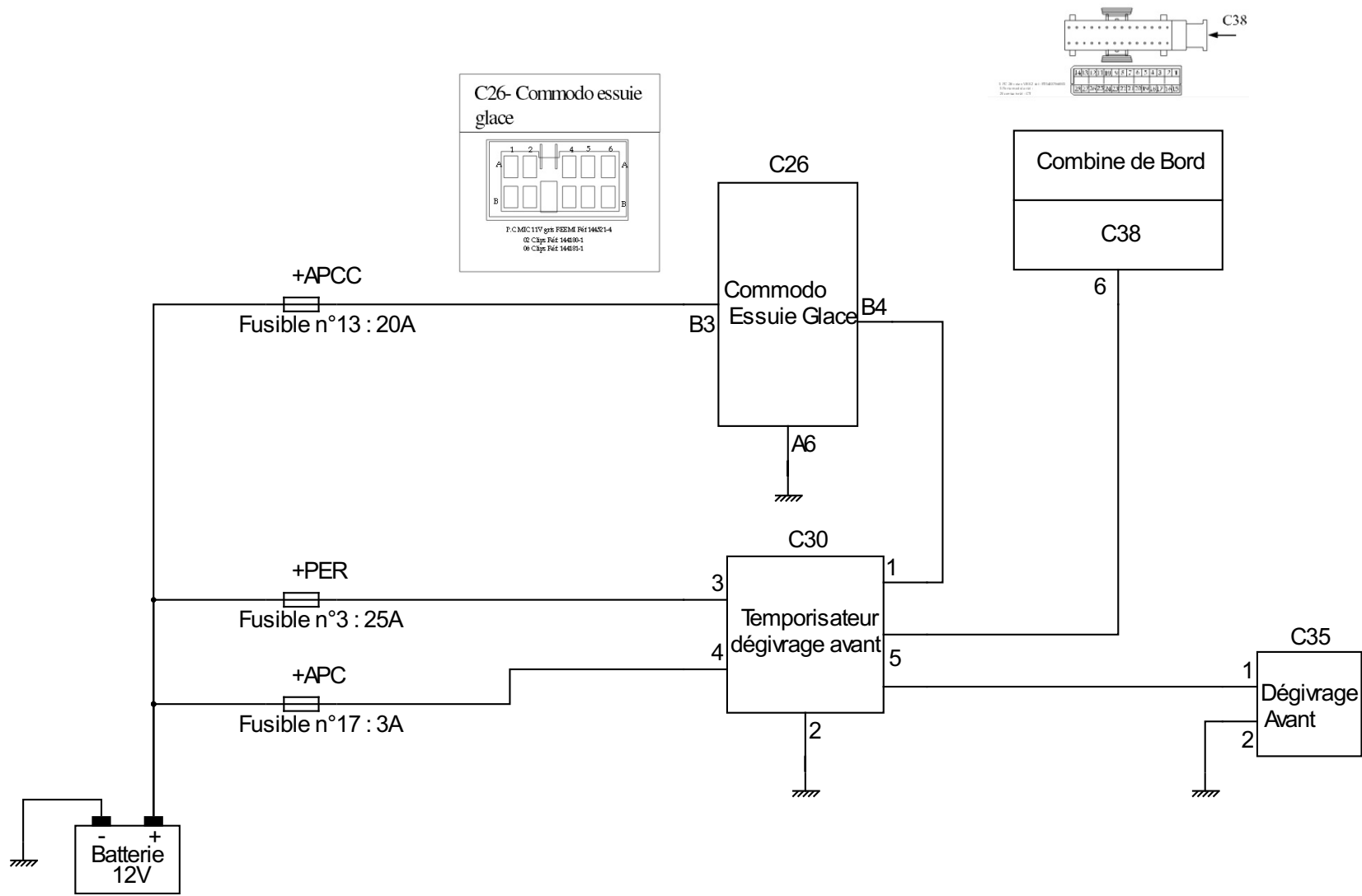

Auteur :
Date :

Dégivrage Avant

Fichier :
Folio : 20/29

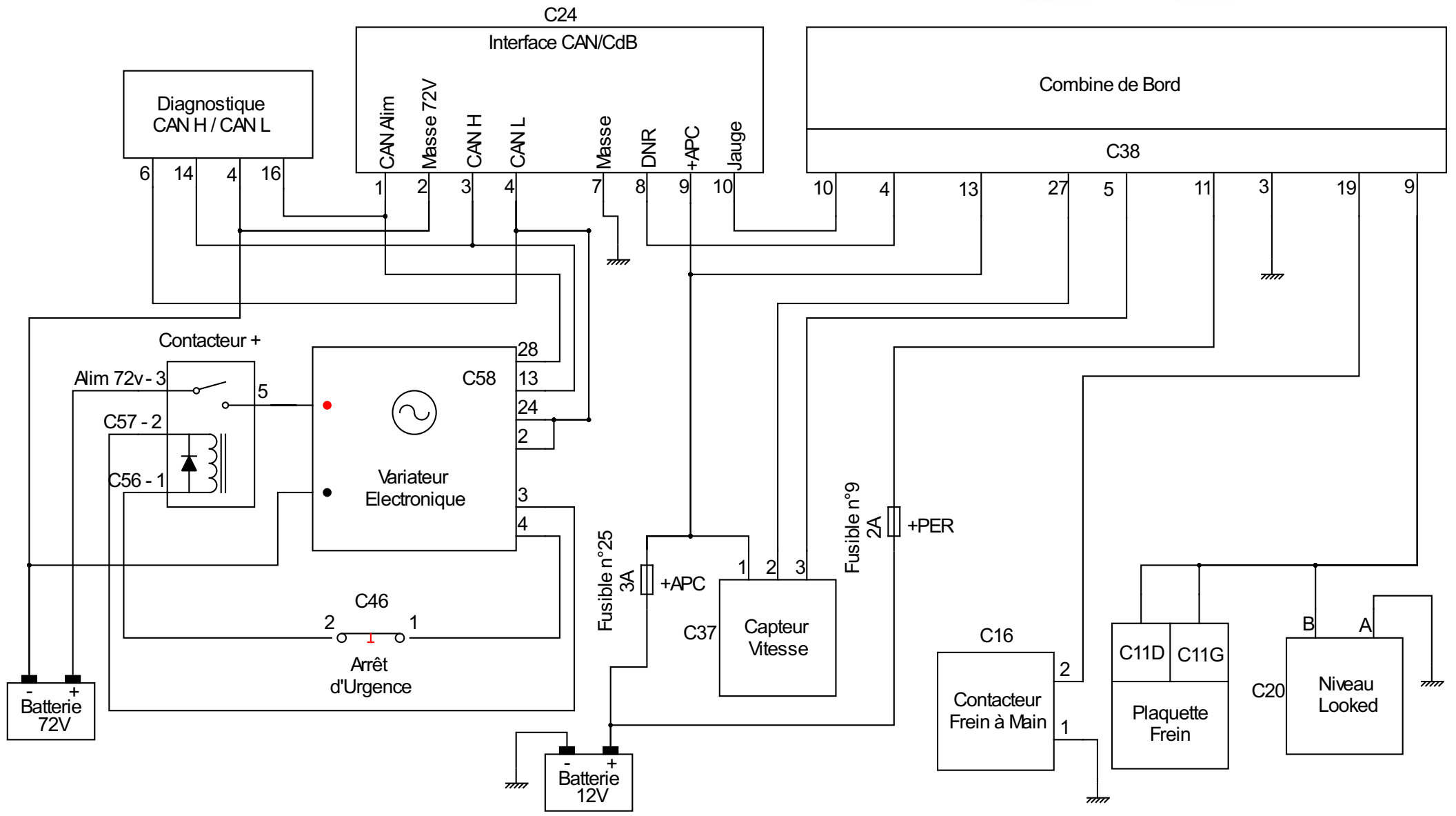
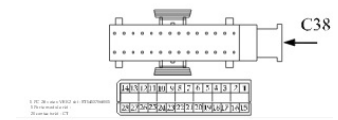

Auteur :
Date :

Voyants Information Combiné de Bord

Fichier :
Folio : 21/29

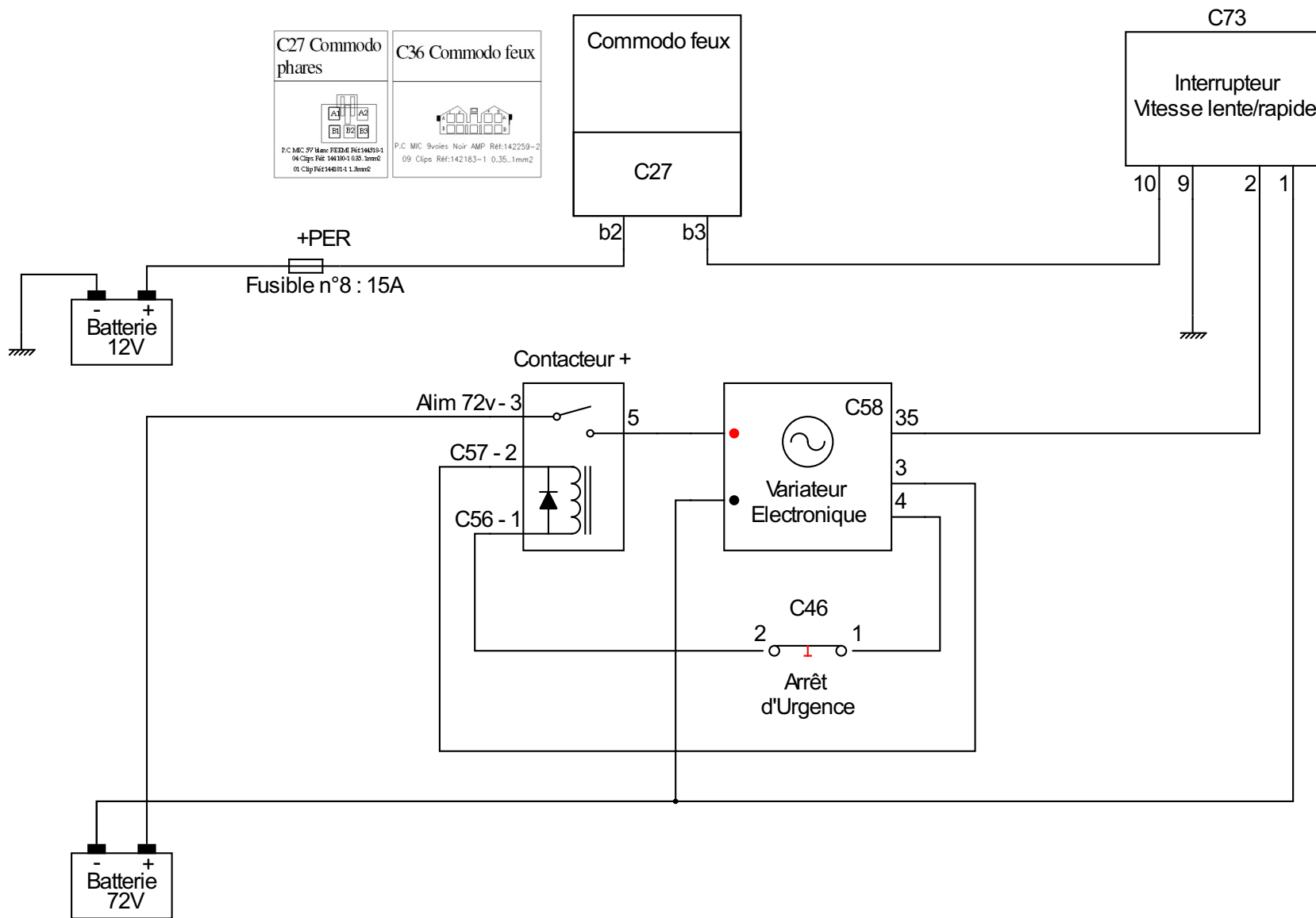

C27 Commodo phares

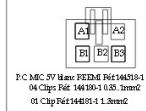

P.C MIC 9V 14mm: FEEDM Réf:144318-1
04 Clips Réf: 144318-1 0.35.1mm2
01 Clip Réf:144318-1 1.3mm2

C36 Commodo feux



P.C MIC 9voies Noir AMP Réf:142259-2
09 Clips Réf:142183-1 0.35.1mm2

Commodo feux

C27

C73

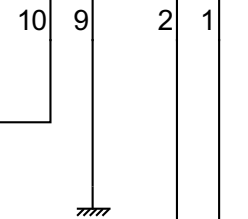

Auteur :
Date :

Régulation Vitesse

Fichier :
Folio : 22/29

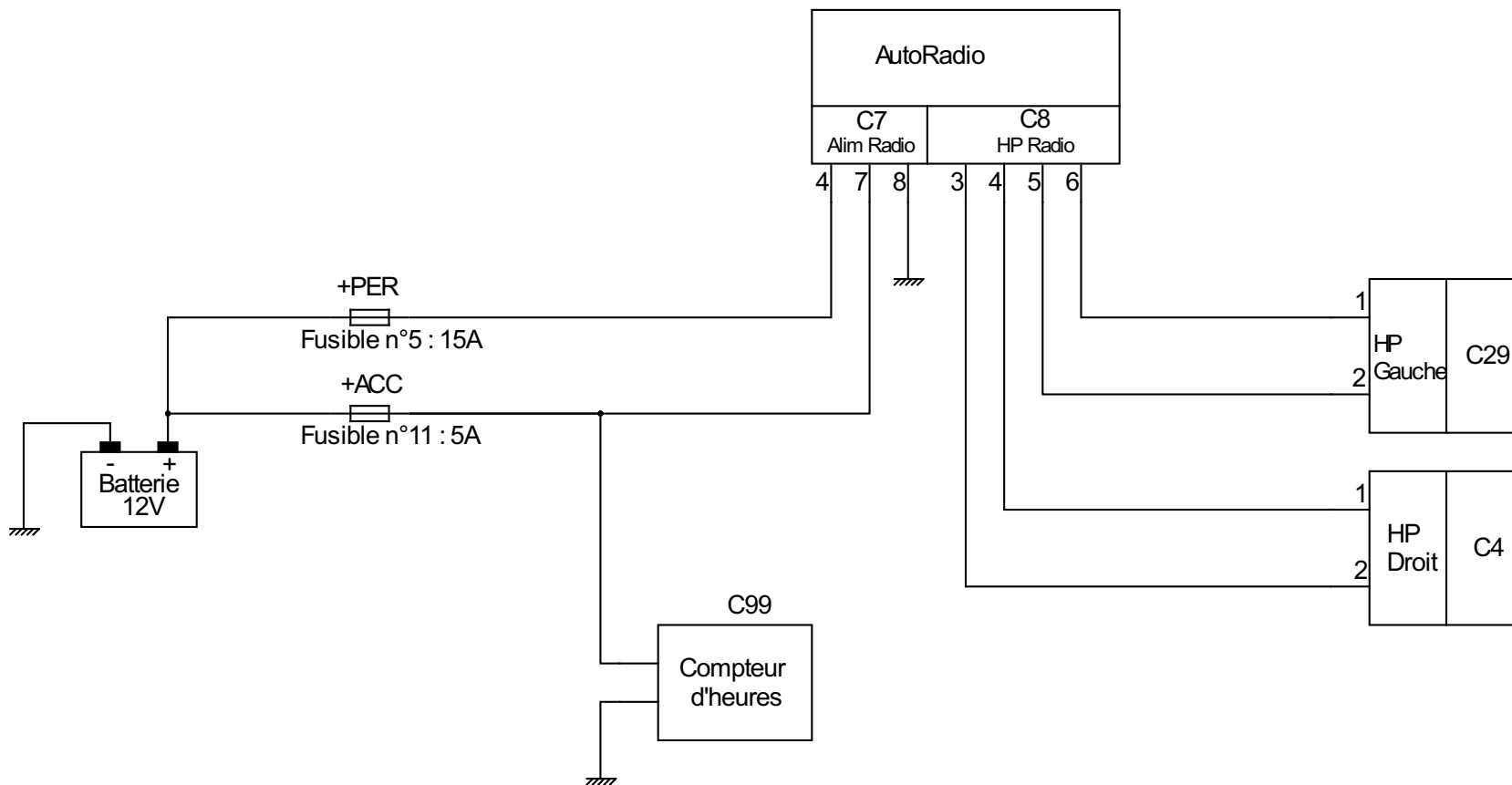

Auteur :
Date :

Auto Radio

Fichier :
Folio : 23/29

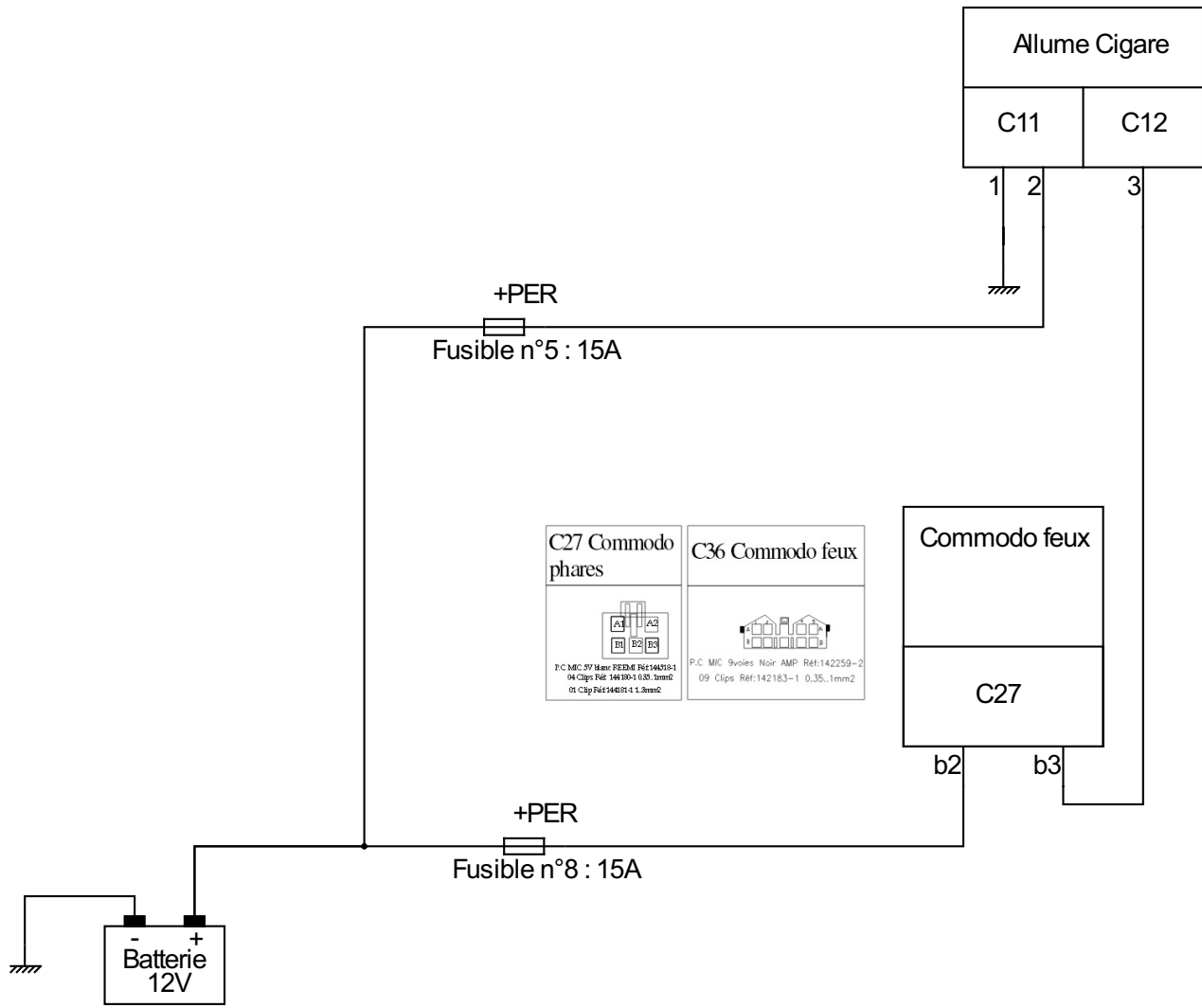

Auteur :
Date :

Allume Cigare

Fichier :
Folio : 24/29

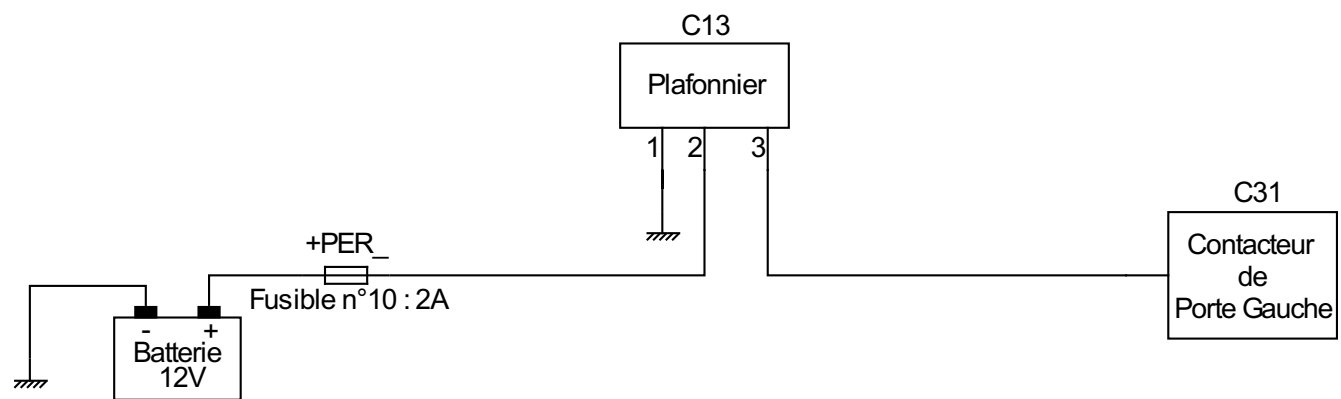

Auteur :

Date :

Plafonnier

Fichier :

Folio : 25/29

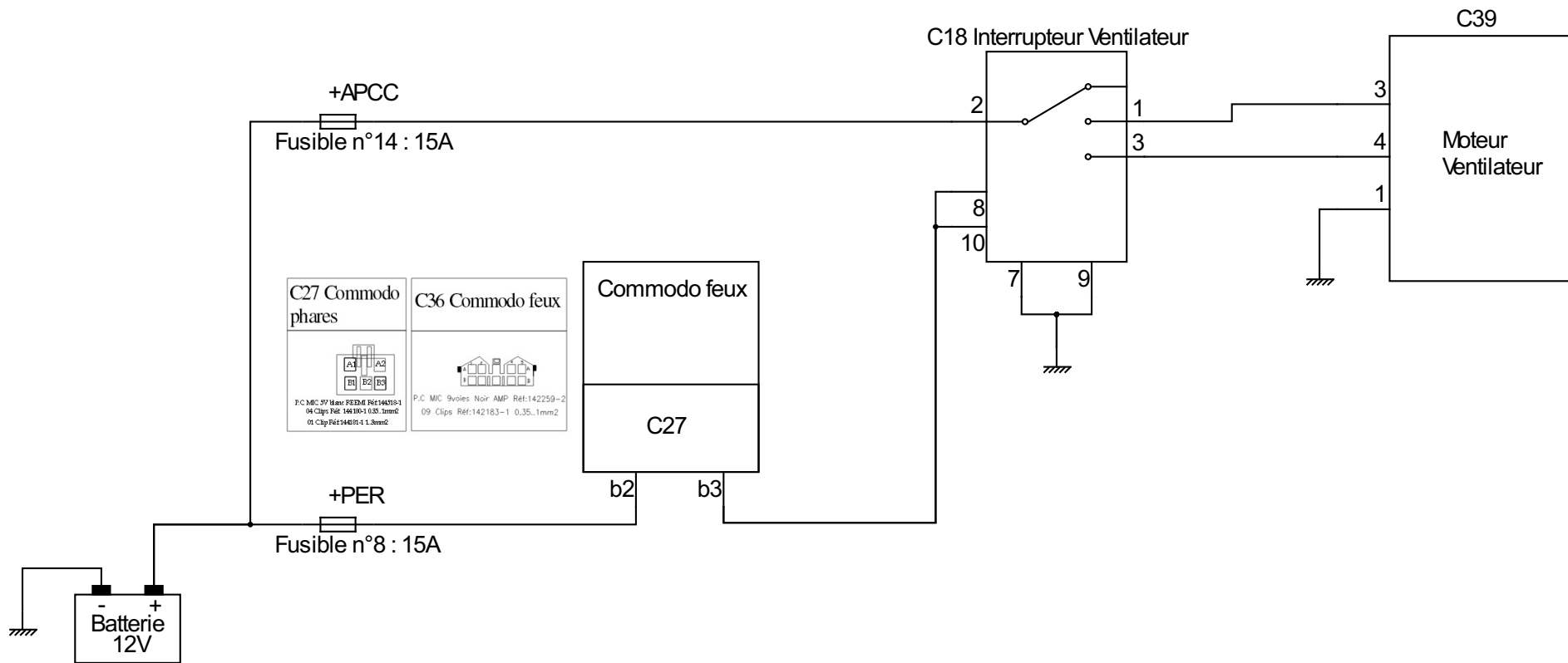

Auteur :

Date :

Ventilation-Chauffage

Fichier :

Folio : 26/29

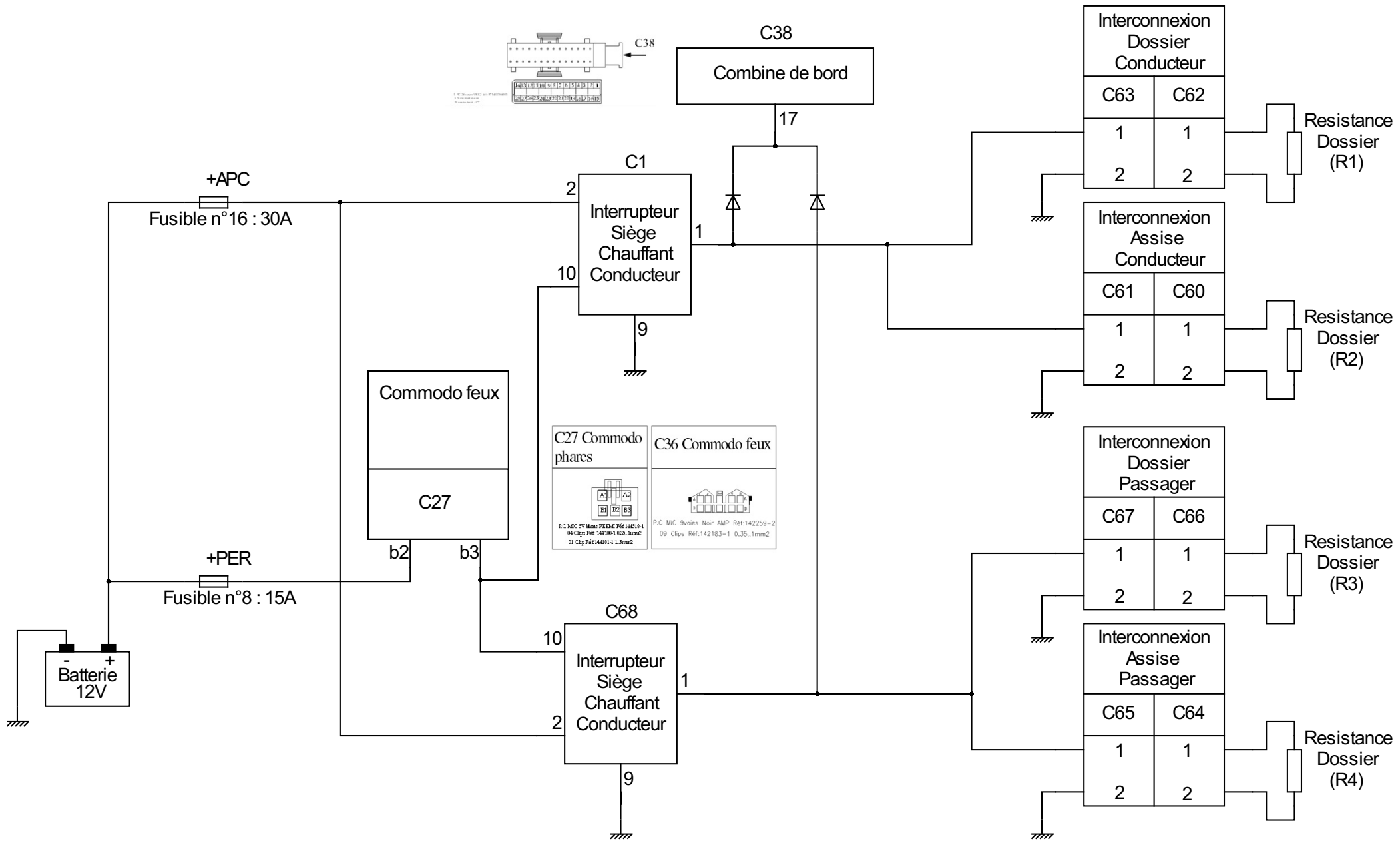

Auteur :
Date :

Siège Chauffant

Fichier :
Folio : 27/29

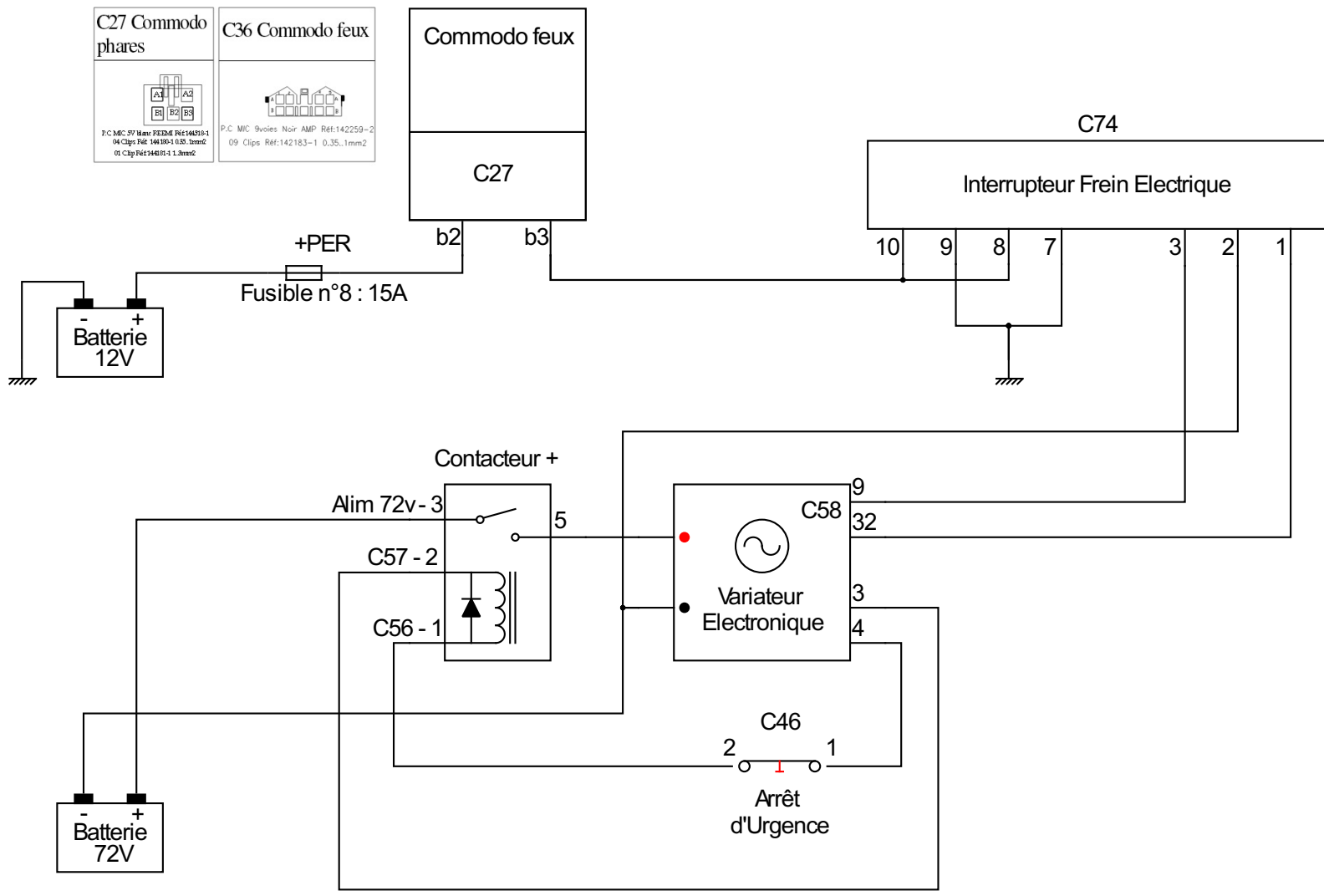

C27 Commodo phares



P.C. MIC 97 Masse F2EDM Réf:144356-1
04 Clips Réf: 144388-1 0,35_1mm2
01 Clip Réf:144381-1 1.3mm2

C36 Commodo feux



P.C. MIC 9voies Noir AMP Réf:142259-2
09 Clips Réf:142183-1 0,35_1mm2

Commodo feux

C27

C74

Interrupteur Frein Electrique

Contacteur +

Alim 72v-3

C57 - 2

C56 - 1

C58

Variateur Electronique

C46

Arrêt d'Urgence

Auteur :

Date :

Frein électrique

Fichier :

Folio : 28/29

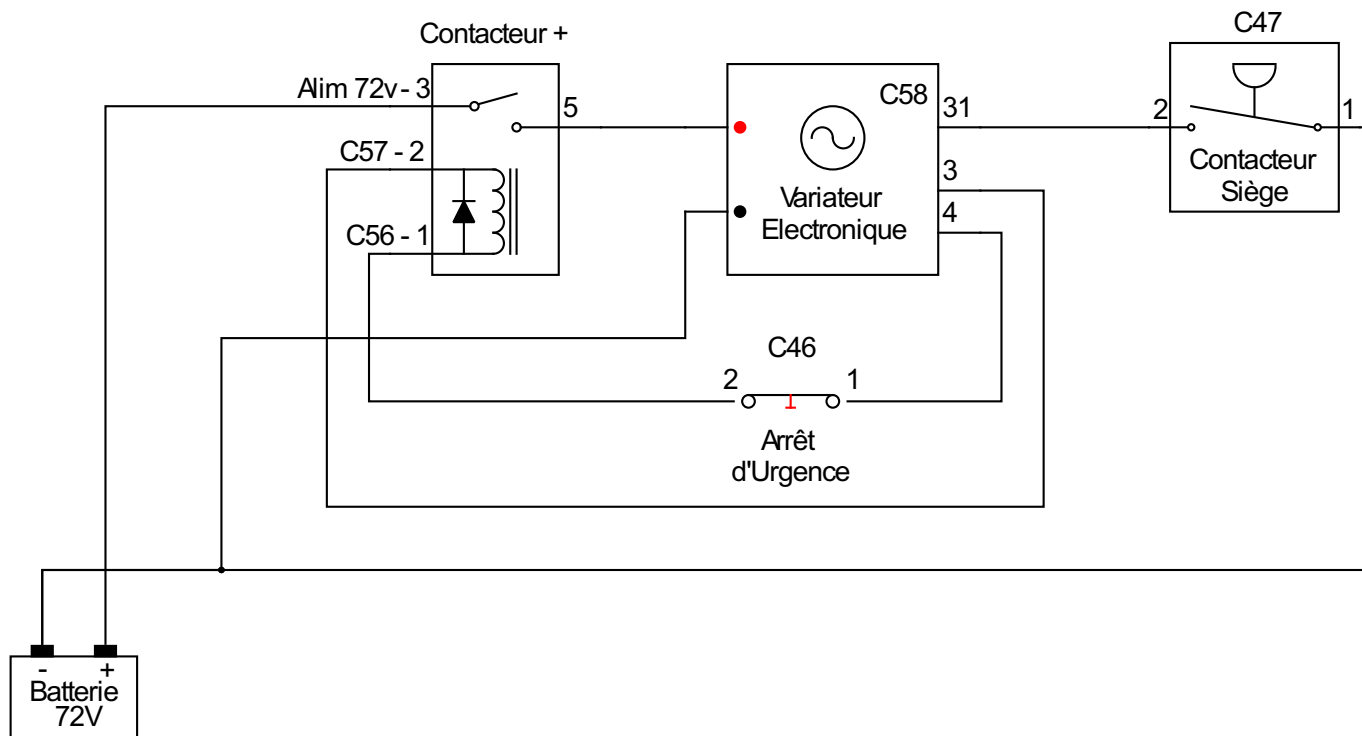

Auteur :

Date :

Alarme Siège

Fichier :

Folio : 29/29

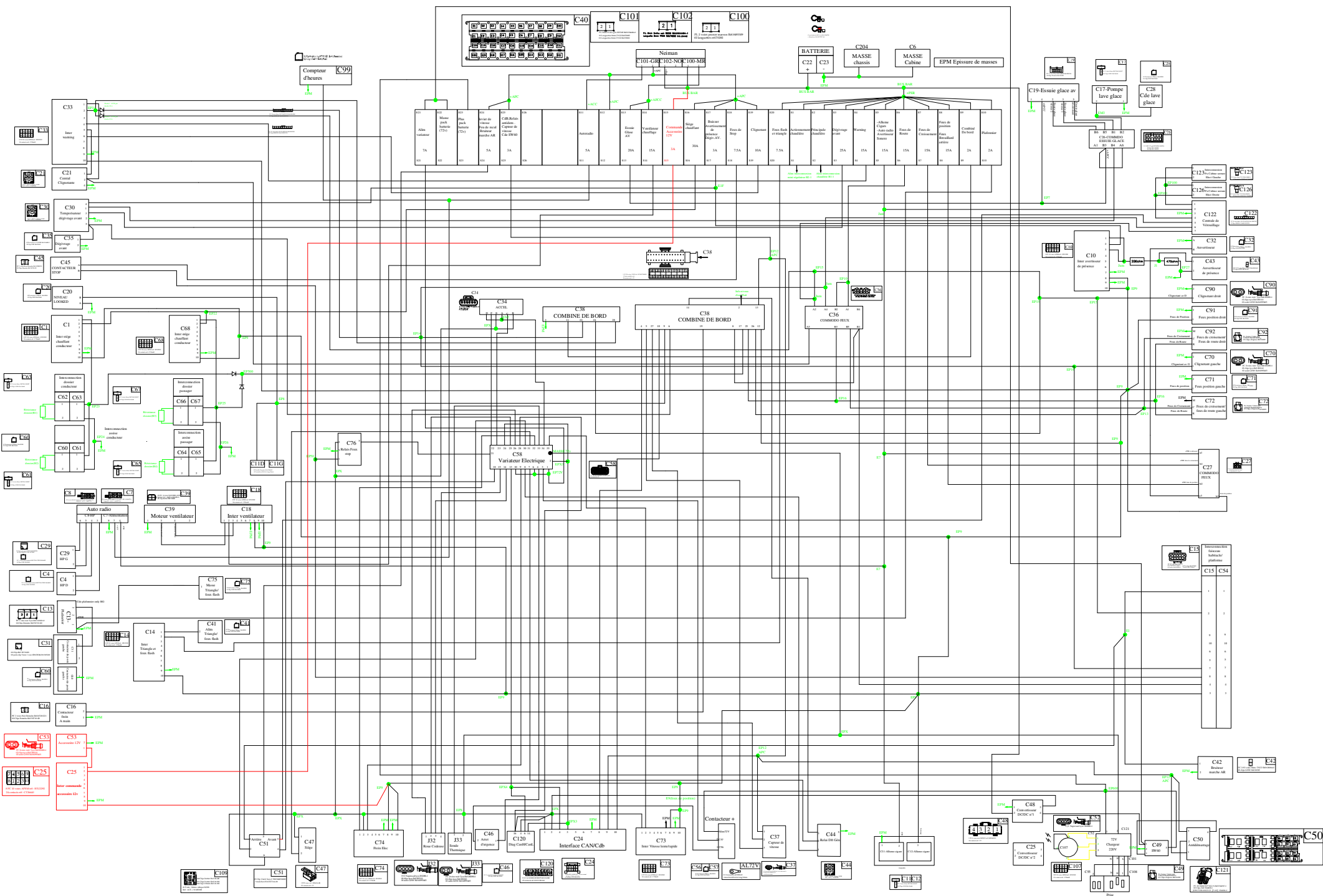

Number	Français	English
Alim 72v	Contacteur +	Main Contactor Power input
C1	Inter siège chauffant conducteur	Driver seat heating switch
C10	Inter avertisseur de présence	Presence bell switch
C100	Neiman	Keyswitch contactor
C101	Neiman	Keyswitch contactor
C102	Neiman	Keyswitch contactor
C107	Témoin chargeur	Charger indicator
C108	Prise 220v	220V plug
C109	Bruiteur feux	Lights ON warning buzzer
C11	Allume cigare	Cigarette lighter
C110	Chargeur 220v	220V charger
C11D	Usure frein d	Right brake wear
C11G	Usure frein g	Left brake wear
C12	Allume cigare	Cigarette lighter back light
C120	Diag CAN L / CAN H	Diagnosis CAN Low / Can High
C121	Chargeur 72v	72V Charger
C13	Plafonnier	Roof light
C14	Inter feux flash et triangle	Beacon lights or warning bar (triangle+2 beacon) switch
C15	Interconnexion habitacle/plateforme	Interconnection cabin / platform
C16	Contacteur frein a main	Handbrake contactor
C17	Pompe lave glace	Windshield washer pump
C18	Inter ventilateur	Fan switch
C19	Essuie glace AV	Front wiper
C2	Feux AR gauche	Left rear light
C20	Niveau looked	Brake fluid indicator
C204	Masse Châssis	Chassis ground
C21	Centrale clignotante	Flasher Unit
C22	Batterie 12v +	+ 12V Accessory Battery
C23	Batterie 12v -	- 12V Accessory Battery
C24	Boitier Interface CAN/CdB	CAN/instrument panel interface box
C25	Convertisseur DC/DC n°2	DC / DC Converter # 2
C26	Commodo Essuie glace	Wiper control
C27	Commodo Feux	Lights control
C28	Cde lave glace	Washer fluid control
C29	HP G	Left speaker
C3	Feux AR droit	Right rear light
C30	Temporisateur dégivrage AV	Front defrost timer
C31	Contacteur de porte gauche	Left door contactor
C32	Avertisseur	Horn
C33	Inter Warning	Warning switch
C34	Pédale d'accélérateur	Throttle
C35	Dégivrage AV	Front defrost
C36	Commodo Feux	Lights control
C37	Capteur de vitesse	Speed sensor
C38	Combiné de bord	Instrument panel
C39	Moteur ventilateur	Fan motor
C4	HP D	Right speaker
C40	Boite à fusibles	Fuse box
C41	Alim feux flash+Triangle	Flash lights or warning bar Power
C42	Bruiteur marche AR	Reverse gear buzzer
C43	Avertisseur de présence	Presence bell
C44	Relai défaut général	Main fault relay
C45	Contacteur stop	Stop contactor
C46	Inter Arrêt d'urgence	Emergency stop switch
C47	Contacteur de présence siège	Seat sensor switch
C48	Convertisseur DC/DC n°1	DC / DC Converter # 1
C48	Convertisseur DC/DC n°1	DC / DC Converter # 1
C49	Pilotage convertisseur SW60	SW60 switch for converter(s)
C50	Anti démarrage	Anti-drive relay
C51	Lever de vitesse	Gear shift
C52	Témoin Chargeur	Charger indicator
C53	Batterie 72v	72V Battery
C54	Interconnexion habitacle/plateforme	Interconnection cabin / platform
C55	Prise 220v	220V plug
C56	Contacteur	Main contactor coil
C57	Contacteur	Main contactor coil
C58	Variateur électronique	Electronic speed controller
C59	Moteur	Motor
C6	Masse Cabine	Cabin Ground
C60	Contacteur de porte gauche	Left door contactor
C61	Interconnexion assise conducteur	Driver seating position interconnection (heating)
C63	Interconnexion dossier conducteur	Driver back seat interconnection (heating)
C65	Interconnexion assise passager	Passenger seating position interconnection (heating)
C67	Interconnexion dossier passager	Passenger back seat interconnection (heating)
C68	Inter siège chauffant passager	Passenger heating seat switch
C7	Auto radio	Radio
C70	Clignotant gauche	Left indicator
C71	Feux position gauche	Left day time running light
C72	Feux de croisement/Feux de route gauche	Left Dipped beam/High beam lights
C73	Inter vitesse lente/rapide	Low/high speed switch
C74	Inter frein moteur	Engine brake switch
C75	Masse feux flash+Triangle	Beacon light or warning bar (triangle+2beacons) ground
C76	Relai feux stop	Brake light relay
C8	Auto radio	Radio
C9	Plaque de police	Registration plate
C90	Clignotant droit	Right indicator
C91	Feux position droit	Right day time running light
C92	Feux de croisement/Feux de route droite	Right Dipped beam/High beam lights
J32	Roue codeuse moteur	Motor Encoder wheel
J33	Sonde thermique moteur	Motor temperature sensor
Masse 72v	Variateur électronique	Electronic speed controller 72V ground
W3	Masse feux AR	Rear light ground

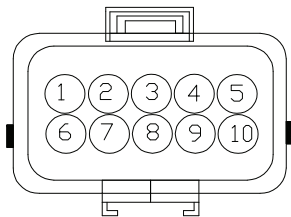

PL 10 voies noir Réf:174657-2
 05 Clips Réf :CT345809-1
 06 seals vert Réf:347874-1
 04 Bouchon Réf:172184
 Verrous réf:DI174658-7
 01 Clip 171662-1

C54 :
 Interconnexion
 habitacle
 /plateforme

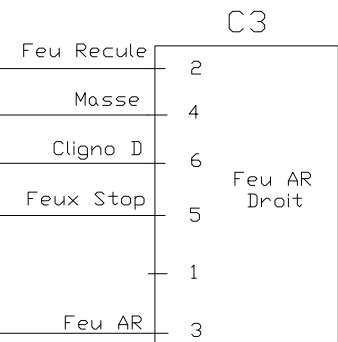
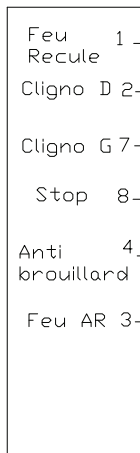

PC 6 voies DEUTCH Réf:DT06-6S
 05 Clips MPS Réf:1062160122
 01 Verrou MPS W6S
 01 Bouchon DI210A015019

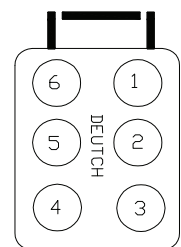

C9

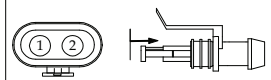
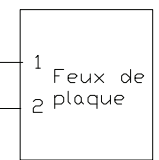

PC 2voies noir Tyco Réf:282080-1
 02 clips tyco Réf:282110
 02 seals GHW Réf:60993403

PC 6 voies DEUTCH Réf:DT06-6S
 05 Clips MPS Réf:1062160122
 01 Verrou MPS W6S
 01 Bouchon DI210A015019

C2

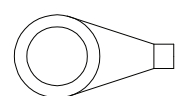
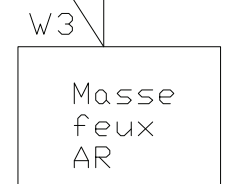
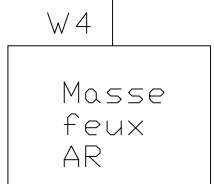
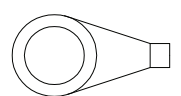
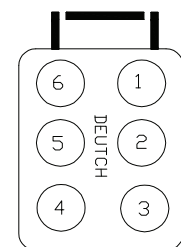
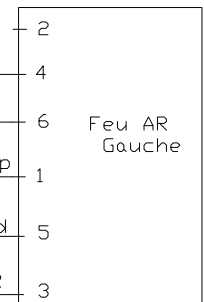

Cosse Ø8mm DEMELEC Réf:CT64689D1208

Réf: 8MP042

cosse Ø4 607044000 + manchon 4.8 L30

Vue d'insertion

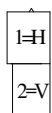

Vue de face

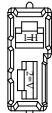

PC282 voies blanc TYCORéf:6260640
02 clips 2.8x0.5 ESCUBEDORéf:430800 Exigence Client

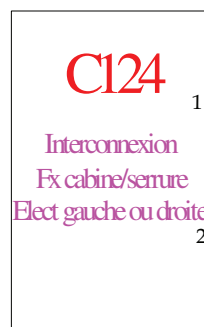

1

2



3

1



PC3 voies noir Tyco Réf:142681-0
02 Clips Demelec Réf:567104D

Réf:	8MP103	
Desig	Faisceau Porte M10	
Plan	Digramme electrique	